

7

---

# **Application & Installation Guide**

## **Lubrication Systems**



# Contents

|  |          |
|--|----------|
| <b>Lubricating Oil Systems</b> .....               | <b>9</b> |
| General Description .....                          | 10       |
| Flow .....   | 10       |
| Engine Sump .....                                  | 10       |
| Main Oil Pump .....                                | 10       |
| Special Marking of Engine Crankcase Dipstick ..... | 10       |
| Oil Coolers.....                                   | 12       |
| D3616/C280-16, FMT.....                            | 12       |
| Oil Cooler Bypass Valve .....                      | 12       |
| Oil Filters .....                                  | 16       |
| Oil Filter Differential Pressure Gauge .....       | 16       |
| Duplex Oil Filters .....                           | 16       |
| Auxiliary Oil Filters.....                         | 16       |
| Supplemental Bypass Filters.....                   | 16       |
| Centrifugal.....                                   | 16       |
| Absorptive.....                                    | 17       |
| Oil Level Gauge (Dipstick) .....                   | 17       |
| Crankcase Breather .....                           | 17       |
| Oil Pressure Regulation Valve.....                 | 17       |
| Priority Valve .....                               | 17       |
| Temperature Regulators.....                        | 18       |
| Gearbox Oil System.....                            | 18       |
| Prelubrication .....                               | 18       |
| Intermittent Prelube System .....                  | 19       |
| Continuous Prelube System.....                     | 19       |
| Redundant Prelube System.....                      | 19       |

|   |    |
|---|----|
| Quick Start Prelube System .....              | 20 |
| Postlubrication .....                         | 20 |
| Optional Systems.....                         | 24 |
| Duplex Oil Filter System.....                 | 24 |
| Remote Oil Filters.....                       | 24 |
| Lubricating Oil Heating System.....           | 25 |
| Oil Makeup Systems .....                      | 26 |
| Oil Pressure Monitoring.....                  | 28 |
| Turbocharger Oil Accumulator.....             | 28 |
| Remote Sump Tanks .....                       | 28 |
| Remote Sump with Gravity Drain .....          | 28 |
| Remote Sump with Scavenging Pump.....         | 30 |
| Piping .....                                  | 30 |
| Suction Strainer .....                        | 31 |
| Auxiliary Sump Tank.....                      | 31 |
| Auxiliary Oil Sump System Considerations..... | 31 |
| Additional Considerations .....               | 33 |
| Supplemental Bypass Filter Systems.....       | 33 |
| Emergency Systems.....                        | 33 |
| Transmissions.....                            | 33 |
| Piping Systems and Flexible Hoses .....       | 33 |
| Lubricating Oil Centrifuges .....             | 34 |
| Centrifuge Supply Pump.....                   | 35 |
| PreHeater .....                               | 35 |
| Sample Points.....                            | 35 |

|   |           |
|---|-----------|
| Lube Oil Storage and Transfer Systems.....    | 35        |
| Clean Oil.....                                | 35        |
| Dirty Oil .....                               | 36        |
| Renovated Oil.....                            | 36        |
| Transfer Pumps .....                          | 36        |
| Storage Tanks.....                            | 36        |
| <b>Lubricating Oil Selection .....</b>        | <b>42</b> |
| Properties.....                               | 43        |
| Viscosity.....                                | 43        |
| Additives .....                               | 43        |
| Total Base Number (TBN) .....                 | 44        |
| Total Acid Number (TAN) .....                 | 44        |
| Cleanliness.....                              | 44        |
| Engine Oil Selection .....                    | 44        |
| Consumption.....                              | 46        |
| Consumption as an Overhaul Guide.....         | 46        |
| Oil Change Interval.....                      | 46        |
| Monitoring Quality .....                      | 47        |
| S•O•S <sup>SM</sup> .....                     | 47        |
| Wear Analysis.....                            | 47        |
| Oil Condition Analysis .....                  | 47        |
| Additional Tests .....                        | 47        |
| Contamination.....                            | 48        |
| Copper .....                                  | 48        |
| Silicon .....                                 | 48        |
| Sodium, Silicates, Carboxylic Acid Base ..... | 48        |

|   |           |
|---|-----------|
| Silicon, Chromium, Iron, Aluminum ..... | 48        |
| Silicon, Lead, Aluminum, Tin.....       | 48        |
| Chromium, Molybdenum, Aluminum .....    | 48        |
| Aluminum .....                          | 48        |
| Iron.....                               | 48        |
| Soot.....                               | 48        |
| Water.....                              | 49        |
| Fuel .....                              | 49        |
| Sulfur .....                            | 49        |
| <b>Reference Material.....</b>          | <b>50</b> |







## Lubricating Oil Systems

Proper lubrication is critical to successful engine operation. The lubrication system of a modern engine accomplishes three primary purposes:

It lubricates surfaces to minimize friction losses.

It cools internal engine parts that cannot be directly cooled by the engine's water-cooling system.

It cleans the engine by flushing away wear particles.

Additionally, the lubricant itself performs other functions:

- It cushions the engine's bearings from the shocks of cylinder firing.
- It neutralizes the corrosive elements created during combustion.
- It seals the engine's metal surfaces from rust.

Lubricating oil systems require clean oil that is free from abrasive particles and corrosive compounds. These systems require a lubricant with sufficient film strength to withstand bearing pressures and heat exposure to cylinder and piston walls. In addition, the lubricant must have a viscosity index that is low enough to flow properly when cold. The lubricant must also be capable of neutralizing harmful combustion products and holding them in suspension for the duration of the oil change period. Your local Cat dealer should be consulted to determine the best lubricant for your local fuels.

The oil system provides a constant supply of filtered oil to the engine. Main bearings, piston cooling jets, camshafts, gear train, rocker arms, and turbocharger bearings are just a few of the components that require proper lubrication for normal function. The oil system is not only for lubrication. Engines equipped with HEUI™ fuel systems use engine oil to drive and control fuel delivery. This makes an effective lubricating oil system particularly important on these engines.

### SECTION CONTENTS

|   |   |
|---|---|
| <p><b>General Description ..... 10</b></p> <ul style="list-style-type: none"> <li>• Lubricating Oil Flow</li> <li>• Lubricating Oil Components</li> <li>• Sample System Diagrams</li> </ul> <p><b>Optional Systems ..... 24</b></p> <ul style="list-style-type: none"> <li>• Optional Lubrication Systems and Components</li> </ul> | <p><b>Additional Considerations.... 33</b></p> <ul style="list-style-type: none"> <li>• Marine/Offshore Requirements</li> <li>• Lubricating Oil Centrifuges</li> <li>• Lubricating Oil Storage</li> <li>• Lubricating Oil Transfer Systems</li> <li>• Sample Sump Configurations</li> </ul> |
|---|---|

---

## General Description

### Flow

A typical engine lubricating oil flow schematic is shown in **Figure 1**.

**Figure 2** and **Figure 3** show the lubricating oil flow for 3600/G3600 engines.

The basic flow of the lubricating oil begins with an engine mounted, gear driven, fixed displacement gear pump. The pump pulls oil from the sump through a coarse strainer on the suction bell. The oil is then pumped toward the oil cooler. Oil cooler flow can differ depending on engine design. Engines designed with an oil cooler bypass valve can divert some of the oil flow around the cooler under certain conditions. The valve operates based on oil viscosity (measured by pressure- drop across the oil cooler). In engines without a bypass valve, the oil flows through the oil cooler. Next, the oil flows to the oil filters. All oil flow is filtered before entering the engine unless the filter becomes plugged. If the filter is plugged, a valve allows the oil to bypass the filter to help prevent lubricating oil starvation. This does not apply to the 3600 or C280. Oil flow proceeds to oil galleries in the engine block where it is distributed to all the components requiring oil flow and pressure. Gravity returns the oil to the sump via drain tubes and passages in the cylinder head and engine block.

Lubricating oil systems may be equipped with additional or optional components. Some components are not available for all engine models, applications and duty cycles.

The following is a brief description of common lubrication system components.

### Engine Sump

The engine sump serves as the engine's main oil reservoir and contains the bulk of the engine oil. Typically part of the engine package, the sump is located below the crankcase to collect the oil as it drains from the engine.

Sumps can differ in capacity, configuration and tilt capability to accommodate various engines and applications.

Tilt capability requires additional consideration for the oil sump to ensure proper lubricating oil system function. Marine and offshore engines may be installed and put into continuous use while in a tilted position. Other mobile applications may require temporary operation in a tilted position.

Caterpillar can provide engines that meet or exceed specific tilt angle requirements. Refer to the Caterpillar TMI for specific information.

### Main Oil Pump

The main oil pump is a gear driven, fixed displacement pump. The pump output depends on engine speed and the effects of changing system restrictions are minimized by the use of pressure regulating valves.

### Special Marking of Engine Crankcase Dipstick

Sometimes marine engines are installed and operated in a tilted position. If the tilt angle is significant

(5° or more) the amount of oil needed to fill the engine crankcase to the full mark on the dipstick (usually marked for level operation) may be more or less than the correct amount the oil pan was intended to accommodate without uncovering the suction bell or flooding the crankshaft seal.

The maximum safe tilt angle is dependent upon the design of the oil sump as well as the dipstick location – both of which are not necessarily uniform for all engine models. Therefore, where a tilted engine installation is encountered it is wise to check and, if necessary, remark the standard dipstick in order to make certain that the high and low marks will really reflect the proper amount of oil for safe engine operation. Oil pressure may be lost due to an uncovered suction bell, a flooded crankshaft seal may leak excessively, and engine vibration can be caused by crankshaft counterweights dipping into the oil. These are all problems that can be caused by an improper amount of oil in the sump.

## Procedure

1. Drain engine crankcase and remove oil filter elements.
2. Install new oil filter elements.
3. Fill crankcase with a given volume of oil ( $V_f$ ) which can be determined as follows.

$$(V_f) = V_r - V_m$$

Where:

$V_r$  = Volume of oil required to refill to Full mark with filter change.

$V_m$  = Volume of oil between Add mark and Full mark for level operation.

**Note:** Both  $V_r$  and  $V_m$  values for a specific engine model are published in the current Technical Marketing Information (TMI).

Add to this any additional oil volume required for special filters, oil lines, or coolers which are additions to the standard engine or unique to the installation.

4. Insert the dipstick to make certain that the oil shows on the dipstick. Be certain that the correct dipstick is used and that it does not hit the bottom of the sump or is otherwise improperly installed.

5. Start the engine and operate it at one half rated rpm until the oil has reached normal operating temperature. Reduce engine speed to low idle and mark the level indicated on the dipstick. This is the add oil or low mark.

6. Add additional oil equivalent to  $V_m$  as shown in the Technical Marketing Information (TMI) and let the engine operate at least another five minutes in order to bring all the oil up to temperature. Mark the new oil level on the dipstick. This is the full oil mark. Refer to Operation and Maintenance manuals for dipstick marking base on installed tilt angles.

## Oil Coolers

The oil coolers are typically shell-and-tube type, with series water flow and parallel oil flow. Some larger engines, however, may use plate-and-frame type for remote cooler applications. Specific cooler designs will vary with engine model and rating.

### D3616/C280-16, FMT

For D3616/C280-16 engines with front-mounted turbochargers (FMT), the oil coolers are installed remotely. These engines are equipped with a different priority valve compared to engine-mounted oil coolers and filters. The maximum line length, total to and from the oil cooler, including off engine filter if present, should never exceed 15 m with a recommended lines diameter of 100 mm (4 in).

Maximum external restriction measured from oil pump outlet to the inlet of the engine-mounted oil filter (includes lines, oil cooler with thermostat, and off-engine oil filter if present) should not exceed 176 kPa. Considering that the engine-mounted eight-element oil filter has approx. 24 kPa restriction, the total restriction allowable is 200 kPa. Failure to follow these instructions can result in oil pressure fluctuations.

The following approximate pressure restrictions on the lubrication system components can be used for planning of the external piping, for oil flow of 1100 lpm at 85°C: oil cooler plate-type heat exchanger - 22 kPa, oil thermostat - 22 kPa, optional duplex off-engine six-element oil filter - 42 kPa, simplex engine-mounted eight-element oil filter - 24 kPa. Total of approx. 110 kPa.

### Oil Cooler Bypass Valve

The oil cooler bypass valve allows oil to flow directly to the oil filters if the oil cooler becomes plugged or if the oil viscosity is high. In this situation, viscosity is determined by the pressure differential across the oil cooler. If the pressure differential exceeds a preset limit, the valve opens allowing oil to bypass the cooler. Cold starts often cause the lubricating oil to bypass the cooler.

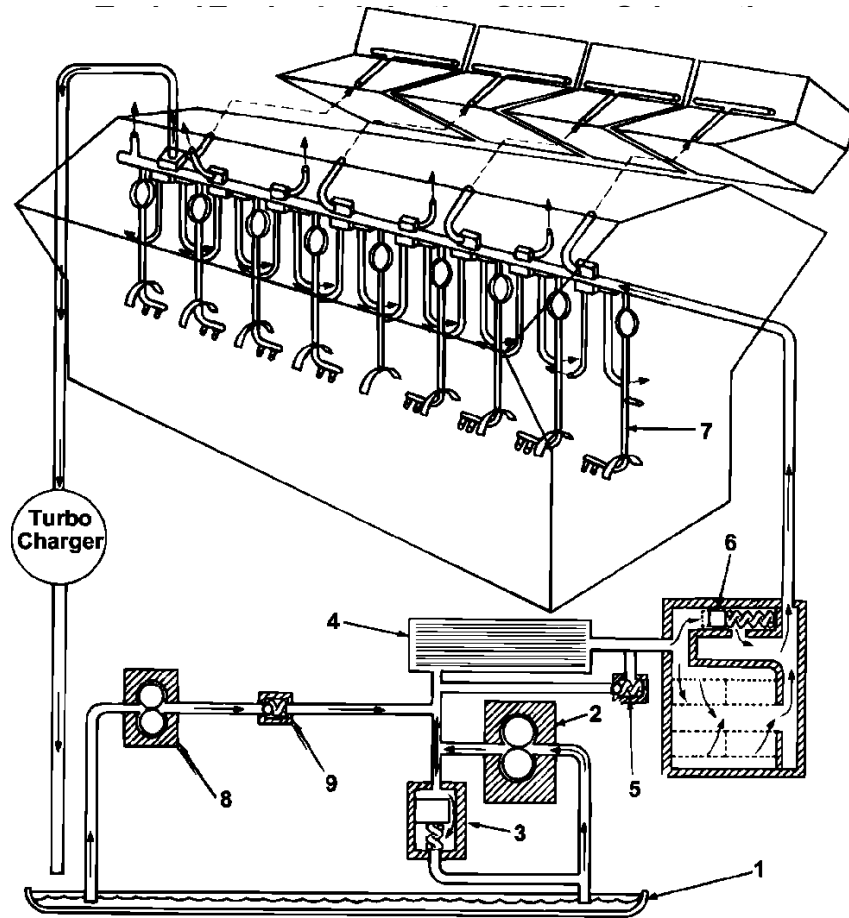

**Figure 1**

1. Sump – lube oil is drawn from the sump through a strainer into the inlet of the lube oil pump.
2. Lube Oil Pump – the quantity of lube oil delivered by the lube oil pump exceeds the engine's needs when the engine is new. As the engine clearances increase through normal wear, the flow required to properly lubricate the engine will remain adequate.
3. Oil Pressure Regulating Valve – this valve regulates oil pressure in the engine and routes excess oil back to the sump.
4. Lube Oil Cooler – the oil to the engine is cooled by jacket water or external water source in the engine oil cooler.
5. Oil Cooler Bypass Valve – when the viscosity of the oil causes a substantial pressure drop in the oil cooler, the bypass valve will open, causing the oil to bypass the cooler until the oil is warm enough to require full oil flow through the cooler.
6. Lube Oil Filter – Cat lube oil filters are the full-flow type with a bypass valve to provide adequate lubrication should the filter become plugged. The filter system may have the replaceable element type or the spin-on type. The oil filter bypass valve is protection against lube oil starvation if the oil filter clogs.
7. Engine Oil Passages – the main oil flow is distributed through passages to internal engine components. The oil flow carries away heat and wear particles and returns to the sump by gravity.
8. Prelubrication Pump – used only during starting cycle.
9. Check Valve – prevents oil back flow through prelubrication pump when the pump is inactive.

### 3600 Lubricating Oil System – Model 3608

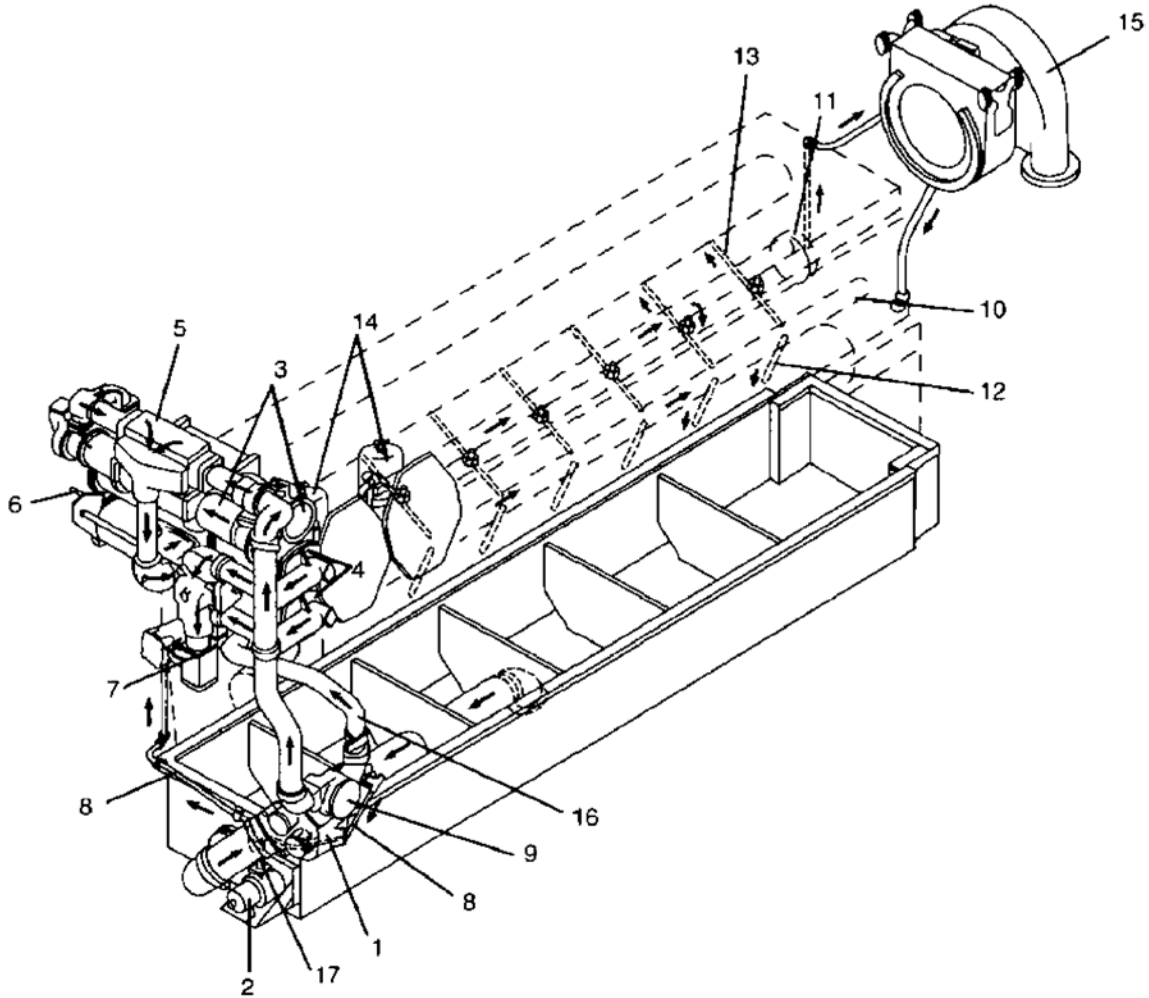

**Figure 2**

- |   |   |
|---|---|
| 1. Oil Pump                               | 10. Oil Manifold (Oil To Piston Cooling Jets) |
| 2. Pre-lube Pump                          | 11. Oil Manifold (Oil To Bearings)            |
| 3. Oil Coolers                            | 12. Oil To Main Bearings                      |
| 4. Oil Filters                            | 13. Oil To Camshafts                          |
| 5. Oil Thermostat Housing                 | 14. Centrifugal Filters (3600 Only)           |
| 6. Oil Filter Duplex Valve Handle         | 15. Turbocharger                              |
| 7. Priority Valve                         | 16. Bypass Oil                                |
| 8. Oil To Centrifugal Filters (3600 Only) | 17. Check Valve                               |
| 9. Emergency Oil Locations                |   |
- \* Flow in Opposite Direction During Pre-lube

### 3600 Lubricating Oil System Schematic - Model 3612

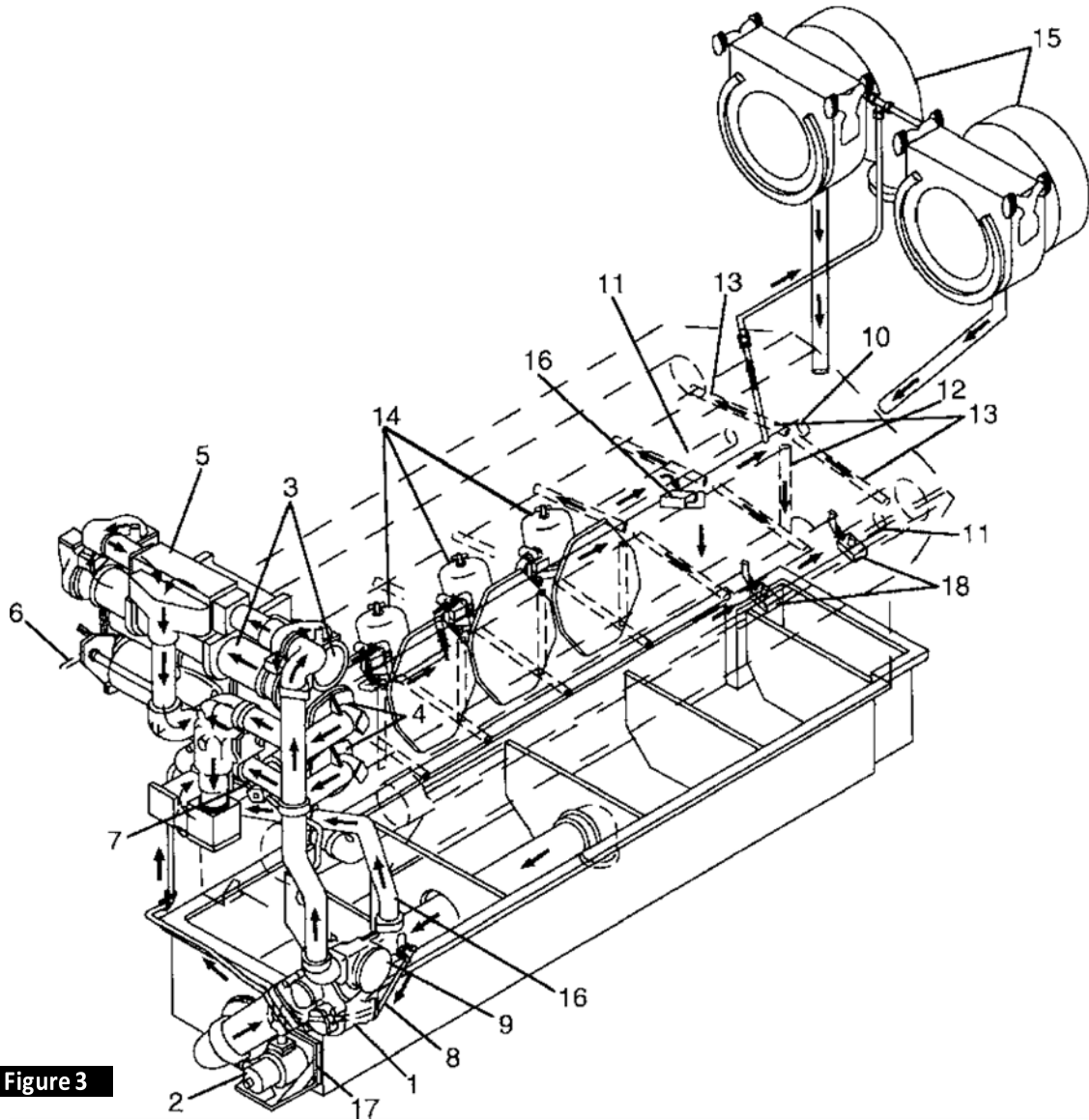

**Figure 3**

- |   |   |
|---|---|
| 1. Oil Pump                                   | 11. Oil Manifold (2) (Oil To Piston Cooling Jets) |
| 2. Prelube Pump                               | 12. Oil To Main Bearings                          |
| 3. Oil Coolers                                | 13. Oil To Camshafts                              |
| 4. Oil Filters                                | 14. Centrifugal Filters (3600 Only)               |
| 5. Oil Thermostat Housing                     | 15. Turbocharger                                  |
| 6. Oil Filter Duplex Valve Handle             | 16. Bypass Oil                                    |
| 7. Priority Valve                             | 17. Check Valve                                   |
| 8. Oil To Centrifugal Filters (3600 Only)     | 18. Piston Cooling Jets                           |
| 9. Emergency Oil Locations                    | 19. Check Valve                                   |
| 10. Oil Manifold (Oil To Piston Cooling Jets) |   |

\* Flow in Opposite Direction During Prelube

## Oil Filters

Cat oil filters are designed to remove solid particles (large enough to cause noticeable abrasion) from the oil by mechanical filtration. Standard oil filter systems on Cat engines meet particulate requirements and are sized to provide reasonable time intervals between element changes.

Filter change intervals should be maintained in line with published service data relating to particular engine models, application and duty cycle.

The use of genuine Cat elements is encouraged for optimum protection of your engine.

## Oil Filter Differential Pressure Gauge

Oil filter differential pressure gauges are available and recommended for many engine models. In most cases the gauges are not integrated into the engine controls, but can be monitored by the operator to protect against engine operation with plugged filters.

Differential pressure gauges are standard on 3600/G3600 lubricating oil systems.

## Duplex Oil Filters

Duplex oil filters can be used instead of standard oil filters on some engine models. In many applications, the use of duplex filters can allow an oil filter change while the engine is operating. Refer to the Optional Lube Oil Systems section for more information.

## Auxiliary Oil Filters

Some Cat rich burn (stoichiometric) gas engines include an auxiliary oil filter. Where applicable, this auxiliary filter is shipped loose and provides added capacity and filtering to the lubricating oil system, providing for longer oil change intervals.

If a deep sump oil pan option is used, the auxiliary filter should be omitted from the system. The auxiliary oil filter may be considered optional on engines equipped with a standard sized oil pan if the oil change interval is reduced. In such circumstances, an oil analysis is recommended to determine the correct oil change interval.

Auxiliary filter capacity varies by engine model, application and duty cycle.

## Supplemental Bypass Filters

Cat engines usually do not require a supplemental bypass oil filter system. However, some unusual operating conditions may cause users to install such a system. Refer to the Special Considerations section for more information.

Supplemental filters generally fall into two categories, centrifugal and absorptive. Centrifugal filters have proved helpful in extending the primary filter life while absorptive filters reduce acids and contaminants in the oil.

## Centrifugal

Used primarily on the 3500 and 3600 diesel engines, engine-mounted centrifugal filters remove micron-size solids from the oil such



as sludge, wear materials, soot and carbonous material.

Centrifugal bypass filters are not recommended for gas engines.

Centrifugal filters can increase the number of operating hours before the primary filters become restricted.

Additional information about centrifugal bypass filters can be found in the Additional Considerations section of this guide.

### Absorptive

Absorptive filters have an absorbent media such as cotton or cellulose fibers which absorb acids, moisture and remove contaminants from the oil.

Supplemental bypass absorptive filters increase oil capacity and may allow oil and filter change periods to be extended. However, the drain intervals cannot be extended arbitrarily. Oil and filter life must be verified by adequate monitoring systems.

### Oil Level Gauge (Dipstick)

The oil level gauge, or dipstick, is marked with graduations that indicate the engine oil level in the sump. Engines that are 32 liters or less must be stopped to check the oil level.

On engines above 32 liters, the dipstick is marked to allow the oil level to be checked while the engine is stopped or running.

Marine and offshore engines are commonly installed and operated in a tilted position. After installation, dipsticks on these engines should be checked for accuracy and recalibrated if necessary.

### Crankcase Breather

The crankcase breather benefits the oil system by equalizing crankcase and ambient air pressures. Refer to the Crankcase Ventilation Application and Installation Guide, Media Number LEBW4958-00 for more information.

### Oil Pressure Regulation Valve

Most engine models utilize an oil pressure regulation valve to regulate the oil pressure in the lubricating oil circuit. Excess oil is routed back to the sump.

### Priority Valve

3600/G3600 lubricating oil systems are regulated by an oil priority valve. Refer to **Figure 4**.

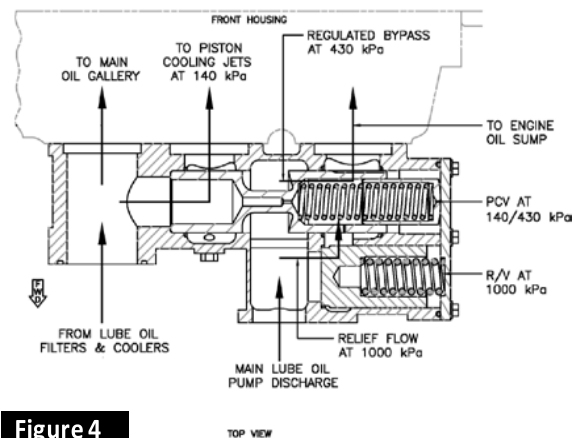

**Figure 4**

The priority valve regulates oil pressure at the cylinder block main oil gallery rather than at the oil pump. This makes the oil gallery pressure independent of the oil filter and oil cooler pressure drops.

The valve also features advanced oil regulating capabilities for better engine protection and lubricating oil management.

## Temperature Regulators

Oil temperature regulators direct lubricating oil to the oil coolers and then oil filters. While most Cat engine models require full oil flow through the cooler at all times, some of the larger engines, notably 3500 engines configured for high jacket water (JW) temperatures and all 3600 engines, utilize a temperature regulator in the oil circuit in order to more closely control the oil temperature.

The 3500 engines, configured for high JW temperatures, cool the oil using the aftercooler circuit instead of the JW circuit. These engines also use an oil temperature regulator in place of the oil cooler bypass valve to avoid overcooling the oil.

Temperature regulators in 3600 engines also help maintain the oil at the optimum temperatures needed for tighter ring clearances and extended ring life associated with the engine.

In either case, oil temperatures are controlled within acceptable limits, provided the cooling system is adequately sized.

**Note:** Oil life will be shortened, and engine components may suffer damage, if excessive oil temperatures are permitted during operation.

## Gearbox Oil System

Some G3500 generator-sets utilize speed increasing gearbox for uses in 60Hz applications. The gearbox uses the same oil as the gas engine. The gearbox uses a shaft driven oil pump that pulls oil from the gearbox oil pan, through the pump, through the filter, through the oil cooler, and then to the gears and bearings.

The gearbox has a sight oil level gauge as well as a port for sampling and comes with an oil heater with thermostat.

For oil temperature regulation, the gearbox utilizes a heat exchanger that is connected in parallel to the engines SCAC circuit. The oil temperature is regulated by using a thermostat in a mixing type application.

The gearbox has oil temperature and pressure sensors installed for safety monitoring by the EMCP controller.

## Prelubrication

Used primarily on larger engines, prelubrication systems lubricate all critical bearing journals before energizing the starting motors. Prelubrication is mandatory equipment for 3600/G3600 engines and especially important after periods of idleness, oil changes and filter changes.

Prelubrication systems are available to operate with electric starter or air starter motors. The systems can be manual or automatic. An automatic system is shown in **Figure 7**.

The manual system requires the engine operator to manually operate a sump pump to fill the engine oil passages before activating the starter motors.

Automatic systems significantly reduce the amount of prelube time prior to engine crank. The prelube pumps may be driven by an electric motor, a compressed air motor, or a compressed natural gas motor (gas engines only), but must be powered from a source independent of any

failure that could require the engine to start. After oil is sensed at the upper portion of the lubrication system, the starter motors are automatically energized.

Automatic prelubrication systems supplied by Caterpillar include starting controls, electric or air powered pumps, a check valve and engine piping. The check valve is used to prevent pressurized oil from flowing through the prelube pump during engine operation.

Refer to the engine model specific price lists for the various options available.

**Note:** Remote mounted prelube pumps must be located and piped to prevent excessive inlet restriction.

Several automatic prelubrication systems available for Cat engines are:

- Intermittent Prelube System
- Continuous Prelube System
- Redundant Prelube System
- Quick Start Prelube System

### **Intermittent Prelube System**

The intermittent prelube system provides suitable performance for applications not requiring quick start capability.

The intermittent prelube system uses an engine mounted pump and is engaged immediately prior to engine start-up.

**Figure 5** is a schematic of a prelube system for a 3600/G3600 engine. The type of prelube pump determines whether the system is intermittent or continuous.

Intermittent prelube time will vary with engine model as well as oil

temperature. A well-designed system must include a prelube pump shutdown capability to prevent the pump from operating too long. Since the intermittent prelube pump operates at a higher flow rate and pressure than the continuous pump, operating the pump for extended time periods is not recommended. This can result in excessive oil in the cylinders and potentially cause hydraulic lock at start-up, and turbocharger seal leakage that can lead to turbocharger damage.

### **Continuous Prelube System**

Continuous prelubrication is for immediate starting applications and is typically used in conjunction with jacket water and lube oil heating.

Used mostly on the 3600 family of engines, a continuous prelube system eliminates the delay of waiting for the completion of an intermittent prelube cycle. This system is operating continuously when the engine is not running. This ensures that lube oil will be available at the bearings at all times, allowing immediate starting of the engine. The continuous prelube systems utilize pumps with lower flow rates than intermittent prelube systems. This system relies on an engine oil level start permissive, in lieu of the pressure switch permissive used with the intermittent prelube system. A minimum level of oil in the engine is required to fulfill the starting system interlock.

### **Redundant Prelube System**

The redundant prelube system combines the continuous and intermittent prelube systems, offering the benefits of both. Under normal circumstances, the continuous

prelube pump keeps the engine ready for immediate start-up by maintaining the level of oil in the engine. The intermittent prelube pump will only operate if the continuous pump fails. This system is typically selected for black start or emergency generator applications, when it is critical that an engine is able to start.

When an engine equipped with a continuous prelube system shuts down, the intermittent pump will postlubricate the engine. After postlubrication the oil pressure decreases and the pilot controlled spill valve opens and the prelube pressure switch opens. When the pressure switch opens the continuous pump will energize and maintain the oil level in the engine.

### **Quick Start Prelube System**

The quick start prelube system consists of two electric prelube pumps, a continuous pump and a booster pump. This system is similar to the redundant prelube system, except that the booster pump is not just a back-up for the continuous pump, it is an integral part of the system.

**Figure 6** and **Figure 7** are schematic examples of quick start prelube systems.

While the engine is not operating, the continuous pump maintains the oil level near the top of the cylinder block via the spill valve. When the engine is started, the continuous pump will stop and the booster pump will start in order to raise the pressure to a sufficient level to permit cranking.

When the engine shuts down, the booster pump will postlubricate. After postlubrication, the oil pressure decreases and the pilot controlled spill valve opens and the prelube pressure switch opens. When the pressure switch opens the continuous pump will energize and maintain the oil level in the engine.

Quick start prelube time will vary with oil temperature. Typical quick start prelube times, measured from the start initiate signal to starter engagement, are 5 to 7 seconds with 25°C (77°F) oil.

### **Postlubrication**

3600/G3600 engines have a standard postlubrication cycle. Postlubrication maintains oil flow after engine shutdown to protect the turbocharger bearings.

Engine postlubrication will not function if the Emergency Stop (E-Stop) button is used to shutdown the engine. Since an oil leak could potentially require the use of the E-Stop button, the postlubrication is disabled to stop oil flow to a possible leak. An E-Stop button is located on the control panel, junction box and the customer terminal strip. Since no postlubrication occurs with the use of the E-Stop button, the E-Stop should only be used for emergency shutdowns.

### 3600/G3600 Engine Lubricating Oil System with Intermittent or Continuous Pre-lube

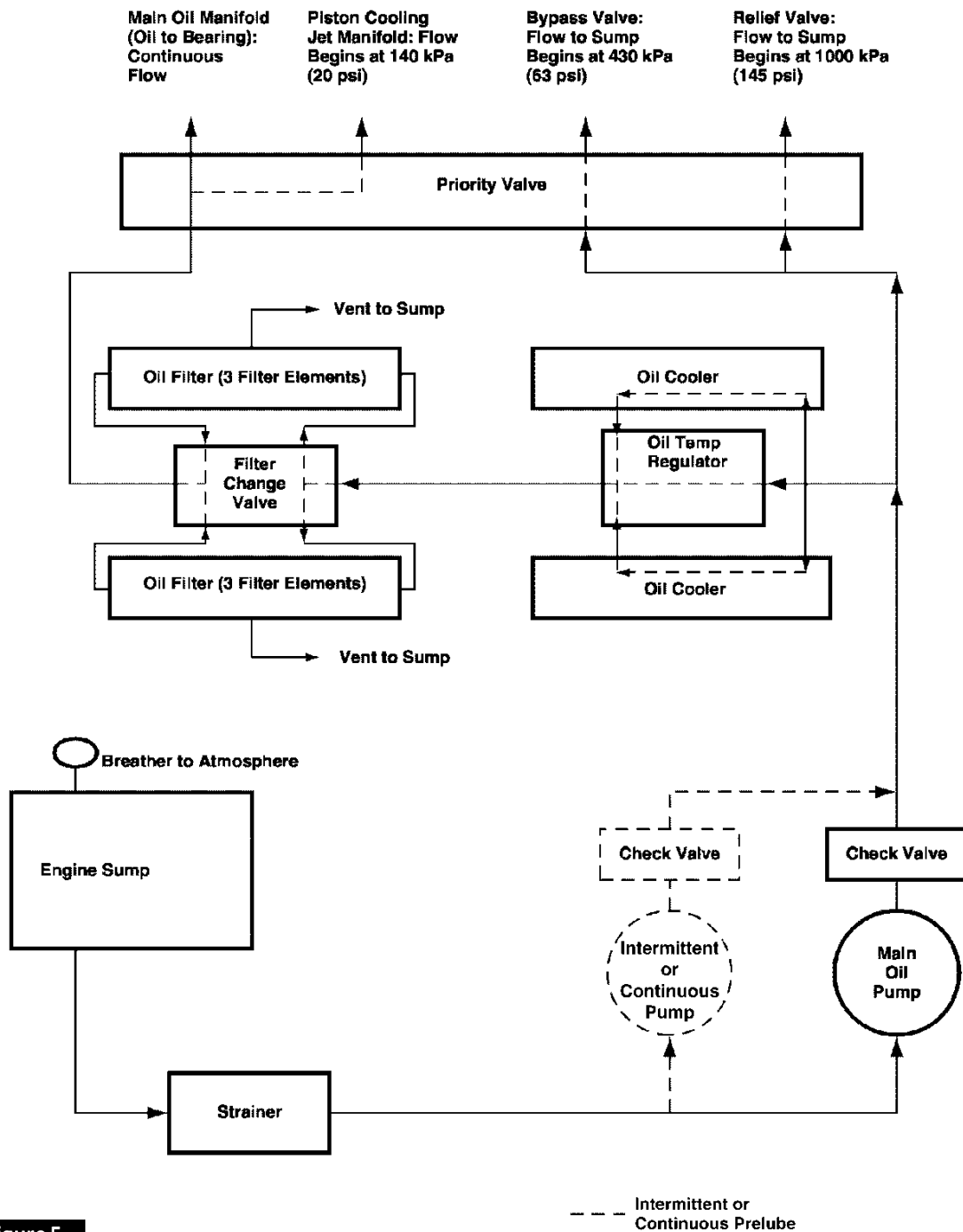

**Figure 5**

### G3600 Engine Lubricating Oil System with Optional Quick Start Prelube

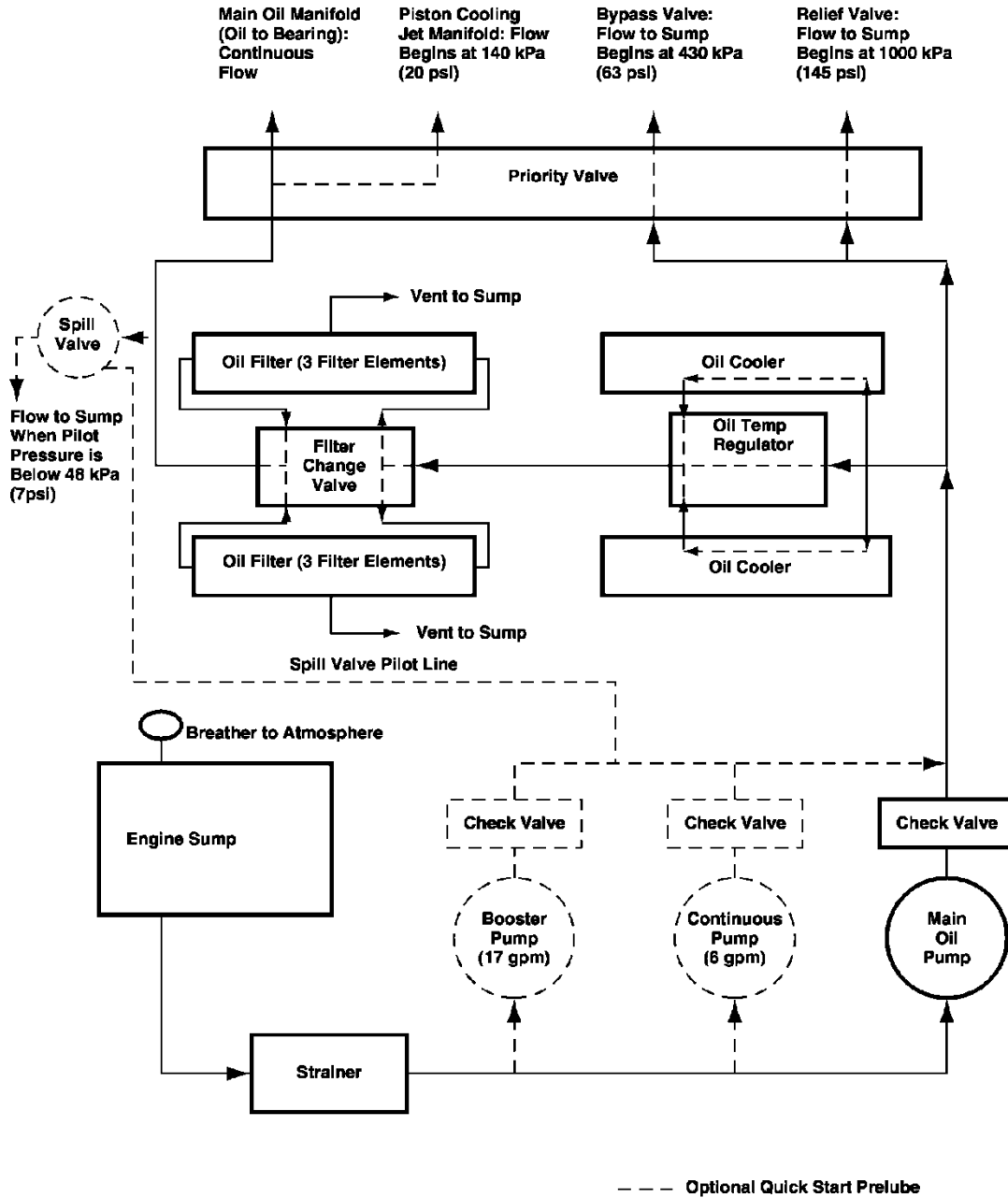

**Figure 6**

### 3600/G3600 Air Prelube

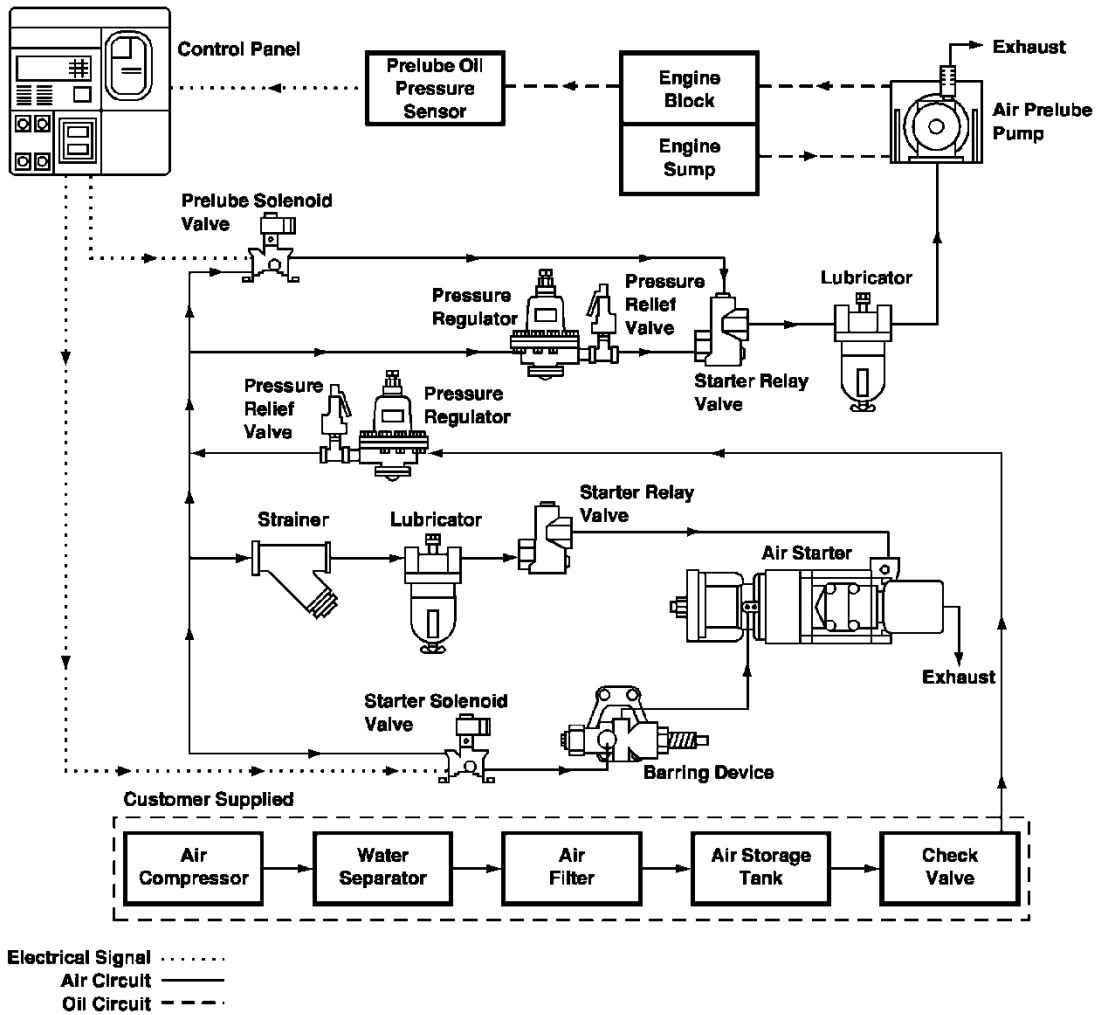

**Figure 7**

## Optional Systems

This section generally describes various lubrication system options available for Cat engines.

Please refer to the engine price lists for availability of these options on specific engine models.

### Duplex Oil Filter System

Many marine and oilfield engines that require marine classification society certification must be capable of oil filter change while running. Changing the filters during operation may also be a customer requirement on certain Electric Power Generation and Industrial applications.

**Note:** Changing oil filters during engine operation should not be performed on engines equipped with unit-mounted radiators and cooling fans. Oil can be blown onto hot engine surfaces and ignite.

The optional Cat duplex oil filter system (one example is shown in **Figure 8** below) meets the requirements of the standard filter system plus an auxiliary filter system with the necessary valves and piping.

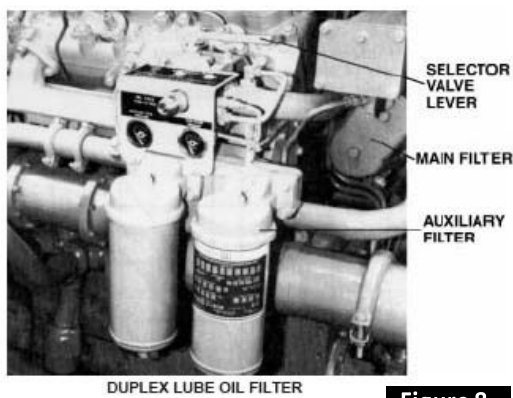

**Figure 8**

The system provides the means for changing either the main or auxiliary filter elements with the engine running at any load or speed. A filter change indicator is included to tell when to change the main filter elements. A vent valve allows purging of air trapped in either the main or auxiliary system when installing new elements.

**Note:** Air must be purged from the changed section to eliminate possible turbocharger and bearing damage. Refer to the engine Operation and Maintenance Manual for purging instructions.

The auxiliary system is capable of providing adequate oil filtration for at least 100 hours under full load and speed operation. The same filter elements are used in both systems.

### Remote Oil Filters

Some Cat engines have the capability for remote mounting the oil filter when space limitation or serviceability is a problem, such as mobile type land drill rigs. However, to protect warranty coverage, authorization from Caterpillar Inc. must be obtained before making any modification to the engine lubrication system.

While remote filters have more potential for oil leaks, they seldom cause problems when the following recommendations are followed:



- Use procedures designed to maintain oil system cleanliness during removal and installation of oil filters and lines. Keep all openings covered until final connections are made. Refer to Caterpillar Flushing and Pickling Guidelines.
- Use quality pipe or medium pressure, high temperature 120°C (250°F) hose that is equivalent to, or exceeds, the SAE 100R5 specification.
- Keep oil lines as short as possible and at least as large as engine connections.
- Support hoses as necessary to keep from chafing or cutting on sharp corners.
- Use care in connecting oil lines so the direction of oil flow is correct.

**CAUTION:** Engine damage will occur if the oil filter is improperly connected.

### Lubricating Oil Heating System

Cold oil has a higher viscosity and flows more slowly through oil passages, reducing its ability to quickly go where it is needed. Cold oil can also place a higher demand on the starting system, requiring higher starting torque. Lubricating oil heating systems address these issues.

On some engines lube oil heating systems are recommended for heating the lube oil to 10°C (50°F) when lube oil is below this temperature. They are also

recommended when quick start capability is required.

Lube oil heating systems are often thermostatically controlled. When the engine is shutdown and the oil drops below the desired temperature, the heating system activates. The heating system stops after the engine is started or the oil has reached the desired temperature.

The Cat lube oil heating system is a prepackaged, shipped loose unit, that may be used as a stand-alone lube oil heater or in combination with a jacket water heater. The typical package includes:

- Circulating pump
- Electric oil heater
- Control panel, including controls for starting/stopping pump, temperature control, etc.
- Piping, valves and fittings on the unit (customer must make piping connections to the engine).

In some limited applications, jacket water heaters in conjunction with continuous prelubrication may satisfy lube oil heating requirements. However, this method of heating should be carefully calculated before implementation.

Another solution that requires careful consideration is immersion heating. Heating elements in direct contact with lubricating oil are not recommended due to the danger of coking. To avoid coking when heating oil, heater skin temperatures must not exceed 150°C (300°F)

and heater elements must have a maximum heat density of  $1.24 \text{ w/cm}^2$  ( $8 \text{ w/in}^2$ ). Marine applications use a variation of an immersion heater when steam is piped through the engine oil sump.

Heating pads, designed for oil preheating, may also be used. These can be used to bring the lubricating oil up to the desired  $10^\circ\text{C}$  ( $50^\circ\text{F}$ ).

### Oil Makeup Systems

Some applications may require that a fixed oil makeup system be installed to ensure that a constant level of lube oil is maintained in the engine sump. In most cases, this is a customer furnished system, but Caterpillar offers oil makeup systems that work with a customer supplied gravity-fed oil supply to maintain a safe and constant oil level. The Cat lube oil makeup system typically includes an oil level regulator and alarm & shutdown switches.

Oil level alarm and shutdown switches alert the operator when low oil levels are present. The oil level alarm should sound when the oil level in the sump drops below the Add mark on the oil level gauge (dipstick). An oil level shutdown occurs when the oil level in the sump drops below an acceptable level in the sump.

It is important to mount the oil level regulator and shutdown switch gauges in the proper location. Failure to properly locate the gauges could result in premature alarm/shutdown conditions or allow the sump oil level to drop far below recommended

levels before the alarm/shutdown is activated. See **Figure 9** for proper mount locations.

Most oil level switches and oil level makeup devices are vented. If vented to the atmosphere, they will regulate to some erroneous level due to the crankcase pressure. The vent line from these devices should go to the crankcase (well above the oil line). There must be no low spots in the vent line that could allow oil to collect and cause a blockage of the vent line.

For an oil makeup system to maintain a constant oil level in the sump, the system should add oil to the sump when the level drops below the Running Full mark on the oil level gauge (dipstick). See **Figure 9** for proper mount location. This automatic system senses the oil level and feeds oil into the sump from a remote oil reservoir as required.

The remote reservoir must be able to feed the oil into the sump at all operating conditions. Some makeup systems are pump operated while others are gravity fed. Depending on the height at which the makeup line enters the oil pan, pressure in the oil pan can range from 0 kPa to 7 kPa (0 psig to 1 psig), so it is important that each system be inspected and tested to ensure proper operation and positive oil flow.

A shutoff valve should also be installed between the remote oil reservoir and the oil level regulator to provide a means for serviceability and maintenance.

The Cat oil makeup system offered on G3600 engines provides a floor-standing, gravity-fed oil makeup system. The system is activated by a float valve if the oil level drops below full running level. A second float valve activates a low/high level alarm if the oil level drops below or exceeds a preset alarm level. A third float valve provides an engine shutdown contact if the oil level drops below a preset shutdown level.

### Locations for Low Oil Level Alarm, Shutdown and Makeup Gauge

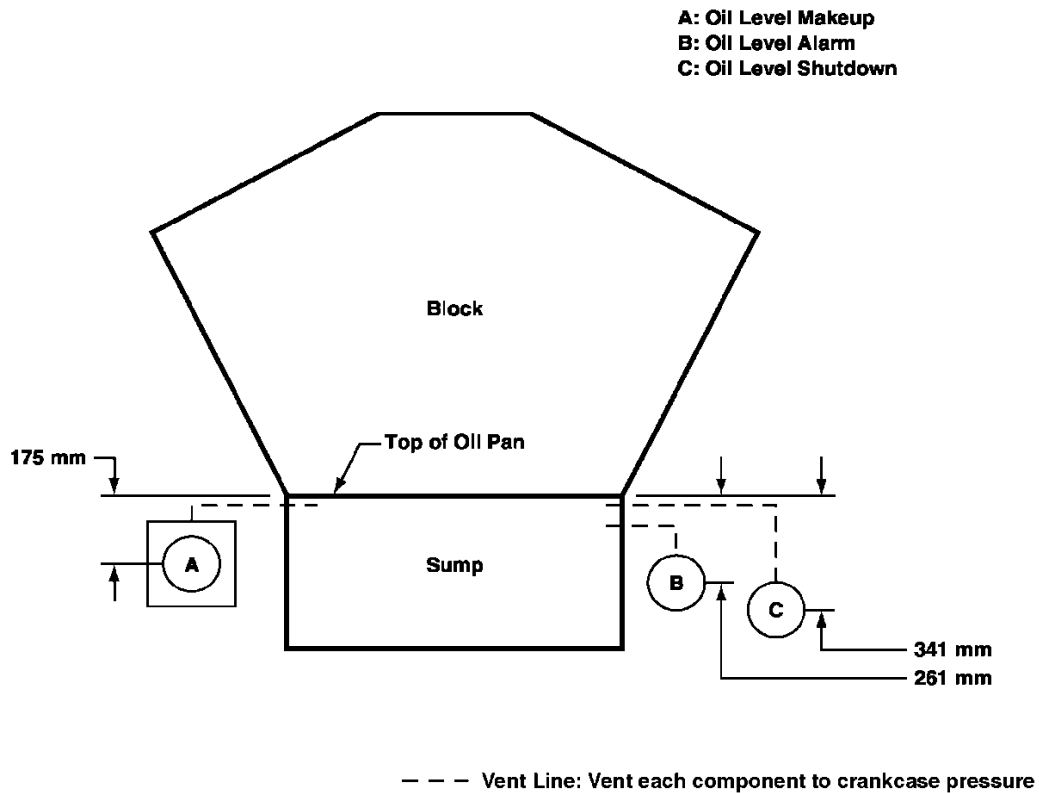

**Figure 9**

## Oil Pressure Monitoring

Maintaining sufficient oil pressure is critical to engine operation. A means of monitoring oil pressure should be used. In some cases, this will be done by the use of oil pressure gauges. Additionally, low oil pressure contactors may be used to shutdown the engine if pressure becomes too low.

Most engines have some level of oil pressure monitoring; refer to the Operation and Maintenance Manual for each engine for available features. Advanced features on some Cat engines include user-switchable options and user-programmable setpoints for Warning/Derate/Shutdown.

The switchable options allow the user to choose how the engine responds to low oil pressure.

The programmable setpoints allow the user to choose when and how the engine responds to low oil pressure.

Default parameters and setpoint values for these functions are available in the Caterpillar TIA, TMI, and Electronic Special Instructions for each engine.

For increased safety, automatic engine shutdown features may not be available on single engine marine or mobile applications where an unexpected engine shutdown may create a hazardous situation.

## Turbocharger Oil Accumulator

Engine models above 32 liters equipped with air-to-air aftercooling (ATAAC) may experience reverse running of the turbocharger upon

engine shutdown. This is caused by high pressure intake air in the heat exchanger flowing back through the turbocharger compressor. The turbocharger oil accumulator provides a supply of oil to lubricate and cool the turbocharger in such a circumstance. The oil accumulator protects and can extend the life of turbocharger bearings.

Turbocharger accumulators are optional equipment on G3500 engines.

## Remote Sump Tanks

Engine room space, tilt requirements or the desire to extend oil change periods, may dictate using a remote oil sump tank. **Figure 12** to **Figure 15** are provided as examples of remote sump tanks.

A common external lube oil tank system for use during standard operation for a multiple engine installation is NOT recommended under any circumstances. While the economics of a common lube oil system can be appealing, the increased risks involved do not outweigh the benefits. In the event of the failure of one engine, all of the engines which share the common lube oil system will be compromised.

## Remote Sump with Gravity Drain

The suggested design of an remote sump tank is shown in **Figure 15**.

The following guidelines should be considered when remote sumps are installed in the engine mounting structure:

- The sump should occupy the entire length of the engine to ensure uniform thermal expansion.
- Flanged, flexible, drain connections should be used at each end of the engine mounted sump to prevent damage from vibration and thermal growth.
- The connections must be compatible with engine lube oil at a temperature up to 130°C (266°F).
- The connections should withstand exposure to fuel, coolant and solutions used to wash the engine.
- Drain pipes from the engine oil sump to the remote sump should terminate below the minimum oil level.
- The engine sump drains should be located as far from the oil pump suction area as possible.
- Each suction pipe should be fitted with a bell mouth to keep pressure losses to a minimum. The maximum available suction lift to the engine driven lube oil pump, including losses in the piping and strainer, must be kept below 1.3 m (51 in).
- The oil should be in the tank for the longest possible time to maximize degassing.
- To provide adequate degassing of the remote sump, a minimum distance of approximately 150 mm (6 in.) must be provided between the top of the tank and the highest oil level expected in the tank.
- Transverse structures in the tank should be configured with air holes and oil passages in the structure must ensure adequate oil flow to the pump suction piping.
- Two 100 mm (4 in) minimum diameter air vent pipes should be located on remote sump tanks. On marine applications, install one vent tube at the forward end of the tank and another at the aft end of the tank.
- Locate collecting sumps on marine applications at the aft end of the tank. When used, a lube oil centrifuge would take oil from the collecting sump, at a level below the main lube oil pump suction pipe, and discharge clean oil back to the sump near the lube oil pump suction piping.
- Prior to filling, the inner surfaces of the remote sump tank must be accessible for cleaning, after initial construction or following repairs.
- Use flanged joints on the suction piping to the lube oil pumps to allow inspection before use.

- The surfaces above the minimum oil level must be corrosion protection coated.
- The tank requires a local sounding tube for determining oil volume as well as a low level alarm contactor.
- On marine applications, a cofferdam should be installed to separate the remote sump tank from the shell.
- Marine sump tanks should also be fitted with a coil to heat the oil to 38°C (100°F). The coil must be manufactured from corrosion resistant material. Heating elements in direct contact with lubricating oil are not recommended due to the danger of coking. To avoid coking when heating oil, heater skin temperatures must not exceed 150°C (300°F) and heater elements must have a maximum heat density of 1.24 w/cm<sup>2</sup> (8w/in<sup>2</sup>).

### Remote Sump with Scavenging Pump

An engine driven scavenging pump can be provided for remote sump applications that do not permit gravity drains. The scavenging pump is used to empty the oil from the engine collection pan into the remote sump; Refer to **Figure 12**. The engine collection pan typically has a very low capacity and excess oil accumulation will result in the crankshaft throws splashing in the oil. This splashing contributes to excessive foaming of the oil and can cause dynamic problems in the

crankshaft during engine operation. Remote sumps with scavenging pumps are normally used where the foundation structure height is small.

Oil from the remote sump is returned to the engine oil system by the engine driven main pressure pump. Due to the importance of the main engine lube oil system, marine societies and/or the owner may require electric, motor-driven standby pumps. This system can become very complex due to the additional pumps, piping and valves. Also, the oil level in the remote sump must be kept below the engine crankcase to prevent oil leak back into the engine during shutdown. This system can also result in a long narrow tank. The space required for such a tank can be put to better use on marine applications. Incorporate the features recommended in the design of the remote sump tank with gravity drain discussed above.

The scavenging pump can not be used on applications requiring the engine driven auxiliary water pump, as it is driven off the same engine drive.

### Piping

Remote sump tank piping must be short with minimum bends and have a continual upward slope towards the pump. This slope helps avoid pump cavitation and keeps suction pressure drops to a minimum. Install a non-return valve in the piping to prevent the oil from flowing backwards when the engine is stopped. The pipes must be supported and have flexible connections at the engine and

auxiliary connecting points. Provide vent and drain connections at the high and low points in the system.

### **Suction Strainer**

Install a suction strainer in the piping between the remote sump and the lube oil circulating pumps. This protects the pumps from large particles that may collect in the tank. It should have a stainless steel basket with 650 micron (0.025 in) perforations and magnetic inserts. A differential pressure gauge should be used to indicate when manual cleaning of the strainer is required.

### **Auxiliary Sump Tank**

If longer oil change periods are desired, consider the use of an auxiliary oil sump tank. Refer to **Figure 10**. Unlike remote sump tanks which replace the engine oil sumps, auxiliary sump tanks supplement the engine oil sump. The auxiliary oil sump is used in addition to the engine's oil sump.

An engine's oil change interval is directly proportional to its total oil quantity, all other factors remaining equal. The oil change interval can be doubled by adding an auxiliary sump with the same capacity as the engine mounted oil sump. This increased capacity doubles the amount of oil available to be contaminated, diluted, or neutralized and allow proportionately longer periods between oil changes.

**Note:** Auxiliary sump tanks can increase the interval between oil

changes. They do not increase the interval between filter changes.

Although the relationship between lubricating oil volume and oil change interval is a reasonable guide, oil analysis should be used to determine oil change intervals for the increased capacity.

### **Auxiliary Oil Sump System Considerations**

- The oil source line should be connected to the auxiliary tank as close to the engine oil pump as possible.
- The auxiliary oil sump tank must be full prior to starting the engine and remain full at all times.
- Upon engine start, the auxiliary oil sump overflows, returning the oil to the engine; exactly compensating for the oil removed through the oil source line to the auxiliary tank.
- Use hoses and fittings as described in Remote Sump Tanks. An orifice may be required in the line to achieve appropriate oil flow for the system.
- A check valve should be installed in the oil pump discharge line. Set the valve to open at 75% of the measured pressure at the line connection point, when the engine is at operating temperature and maximum operating speed.

### Auxiliary Oil Sump Connection Schematic

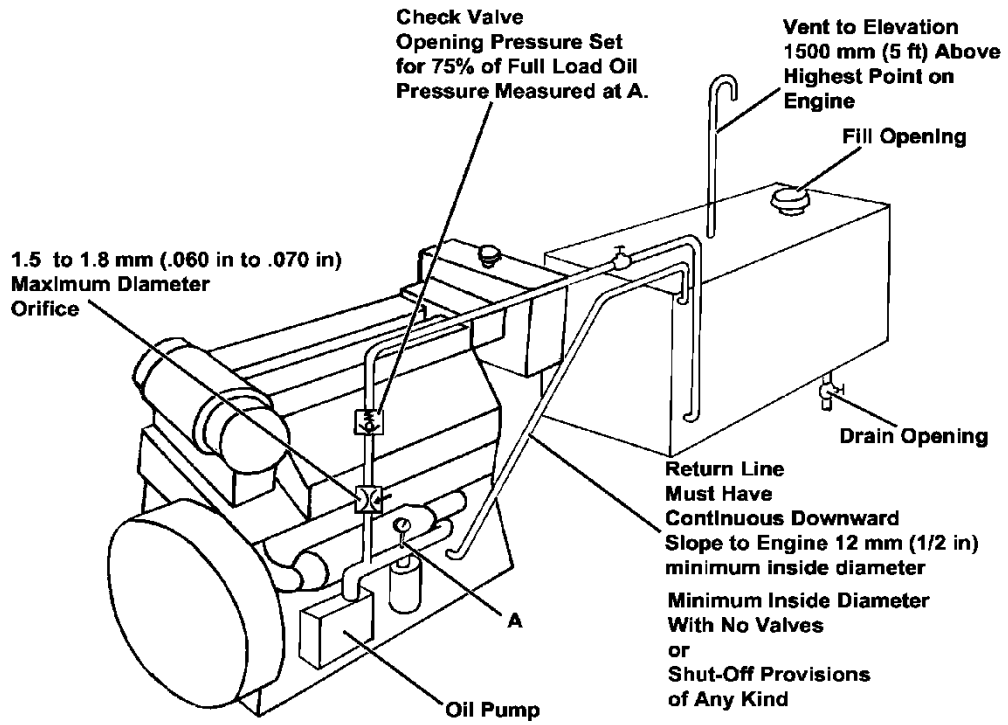

**Figure 10**



## Additional Considerations

This section generally describes additional systems and components that are not part of Caterpillar standard or optional lubrication systems. However, these systems may be required for successful engine or package application and installation.

### Supplemental Bypass Filter Systems

If supplemental centrifugal or absorptive bypass filters are used, the system must have a non-drainback feature in place for engine shutdown. A 3.175 mm (0.125 in.) maximum diameter orifice, limiting flow to 7.57 lpm (2 gpm), must also be used. Refer to engine general dimension drawings for recommended bypass filter supply location and oil return to the crankcase.

### Emergency Systems

Many standby generators, fire pump and marine applications require the capability to connect an emergency lubricating oil pump into the engine's lube oil system. Many Cat engines can be provided with these optional connections when necessary.

This is a specific requirement of marine classification societies for seagoing single propulsion engine applications. The purpose is to ensure lubricating oil pressure and circulation in the event of an engine lubricating oil pump failure. The emergency oil pump allows the single propulsion engine to operate

and the ship to reach port for engine repairs.

Guidelines for emergency lubricating oil system operation:

- Keep pressure drops to a minimum by using short, low restriction lines.
- Use a line size at least as large as the engine connection point.
- Install a low restriction strainer in front of the emergency oil pump.
- Install a low restriction check valve between the emergency pump discharge and the engine inlet connection.
- Use a pressure limiting valve in the emergency system set at the maximum oil pressure limit of the engine.

### Transmissions

Marine classification societies that require emergency lubricating oil pumps for single propulsion engine applications also require emergency lubricating oil pumps for the associated marine transmissions to meet the unrestricted service classification. In these cases, refer to the transmission manufacturer's operation manual for instructions, oil flow and pressure requirements and follow the guidelines listed above.

### Piping Systems and Flexible Hoses

In addition to the emergency lubricating oil system requirements

described above, marine classification societies have specific requirements relating to the materials used in the installation of these systems. Although these systems are not typically offered by Caterpillar, they are still critical to the overall success of a given installation. Therefore, piping system and flexible hose material considerations are discussed in the Piping Systems section of this guide.

### Lubricating Oil Centrifuges

Cat engines are provided with attached lubricating oil filters and in some cases, centrifugal bypass filters. However, customer-supplied centrifuges or separators can also be installed in certain applications. Lubricating oil centrifuges are commonly used in marine and offshore applications, where the availability of clean oil may be limited.

Caterpillar does not offer a centrifuge as part of its standard package and recommends that a reputable centrifuge manufacturer be consulted to ensure proper equipment selection, application and installation. Centrifuge size is typically based on the power output of the engine. Due to frequent cleaning requirements, the centrifuge should be self-cleaning. Solid bowl separators must not be used for lube oil service. The fresh water and control air requirements for the centrifuge should be specified by the manufacturer. The sludge discharge process should be automatic, with the sludge tank arranged to accept

direct gravity feed from the centrifuge.

There are two basic methods for configuring the lubricating oil centrifuge system. The first method is to supply each engine with its own centrifuge.

**Figure 14** and **Figure 15** include a typical lubricating oil centrifuge system. The second method is to service up to four engines with a single lube oil centrifuge. Certain requirements must be met in order to use a single centrifuge for multiple engines. These requirements are:

- All precautions must be taken to minimize sump cross-contamination. This includes locating the changeover manifold at the centrifuge.
- Programmable Logic Controllers (PLC) and automatic valves must be used for the changeover of sumps.
- No more than four oil sumps per centrifuge may be used.
- A redundant centrifuge and the necessary piping and valves, must be incorporated into the design of the application.
- The centrifuges should be oversized.
- Consult Caterpillar for a specific project or application.

The centrifuge should take oil from the rear of the engine and return it to the front of the engine, so that clean oil is as close to the engine oil

pump suction as possible. Shutoff valves can be provided for customer connection, but flexible connections must be provided by the customer.

### Centrifuge Supply Pump

The centrifuge supply pump can be either direct driven from the centrifuge or electric motor driven, but is typically part of the centrifuge package and is sized accordingly.

### PreHeater

The centrifuge preheater is also a part of the centrifuge package and its size is determined by pump capacity and required temperature rise between the sump and the final centrifuge. The final outlet temperature is determined by the centrifuge manufacturer, but will range between 80° and 90°C (176° and 194°F), depending on the grade and type of oil used. Other heater sizing considerations are:

- Oil temperature should be 98°C (210°F) for engines centrifuging during engine operation.
- If the centrifuges operate when the engines are not running the heater must be oversized to account for the heat normally supplied by an operating engine.
- The heater must be thermostatically controlled to maintain the oil temperature to the centrifuge within 2°C ( $\pm 4^\circ\text{F}$ ).

**Note:** Heating elements in direct contact with lubricating oil are not recommended due to the danger of coking. To avoid coking when

heating oil, heater skin temperatures must not exceed 150°C (300°F) and heater elements must have a maximum heat density of 1.24 w/cm<sup>2</sup> (8w/in<sup>2</sup>).

### Sample Points

Check the centrifuge efficiency by drawing samples from points upstream and downstream of the centrifuge. **Figure 11** shows a typical sampling connection.

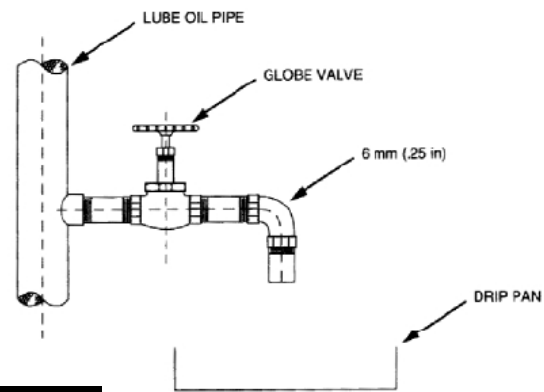

**Figure 11**

### Lube Oil Storage and Transfer Systems

**Figure 13** and **Figure 14**, at the end of this section, show typical piping schematics for an operational lubricating oil storage and transfer system.

The system consists of three storage tanks, a centrifuge system and a transfer pump arranged as follows:

#### Clean Oil

Clean oil from the storage tank is piped to supply the engine sump (or sumps), either by gravity, via the centrifuge, or by the transfer pump.

### Dirty Oil

Dirty lube oil is removed from the engine sump (or sumps), by the transfer pump and discharged to the dirty lube oil storage and settling tank.

### Renovated Oil

Contaminated oil can be cleaned using the lubricating oil centrifuge and discharged to the renovated oil tank.

### Transfer Pumps

The lube oil transfer pump is used to move oil from the engine sump (or sumps), the clean oil storage tank, the dirty oil storage and settling tank and the renovated oil tank. The pump can discharge oil to the dirty oil storage and settling tank, the sludge tank and the engine sump (or sumps).

The transfer pump should be a gear-type pump and include a relief valve. Transfer pump sizing is based on project specific requirements. The following transfer pump characteristics are provided only as a sample.

- Pump Flow Rate – 190 lpm (50 gpm)
- Pump Pressure - 345 kPa (50 psi)
- Operating Fluid Temp. – 130°C (266°F)
- Viscosity for sizing electric motor – 1000 cSt

### Storage Tanks

Each tank should be configured with the following:

- Fill Port
- Vent Location
- Local Sounding Port
- Gauge Glass
- Heating Coil
- Thermometer (with well)
- Transfer Pump Suction Port
- Drain Port
- Steam Blowout Port
- Manhole
- Ladder (if required)

Heating coils should raise the lubricating oil temperature to approximately 38°C (100°F). When heating with steam or water, the heating coils must be manufactured from corrosion resistant material.

**Note:** Heating elements in direct contact with lubricating oil are not recommended due to the danger of coking. To avoid coking when heating oil, heater skin temperatures must not exceed 150°C (300°F) and heater elements must have a maximum heat density of 1.24 w/cm<sup>2</sup> (8w/in<sup>2</sup>).

The engine can be filled with oil from the storage tank via the centrifuge, by the transfer pump (with a strainer), through the forward or aft simplex drain valves, or through the filling cap located on the engine crankcase cover.

Many variables go into establishing tank capacity. The number of engines installed, sump volume and lubricating oil consumption are just a few. The lubricating oil storage tank capacity table is provided only as a sample to show the size relationship between tanks.

| <b>Tank Volumes</b>                 | <b>Liters</b> | <b>Gallons</b> |
|-------------------------------------|---------------|----------------|
| Lubricating Oil Storage Tank        | 7500          | 2000           |
| Dirty Oil Storage and Settling Tank | 3750          | 1000           |
| Renovated Oil Storage Tank          | 3750          | 1000           |

### Remote Lube Oil Sump Arrangement

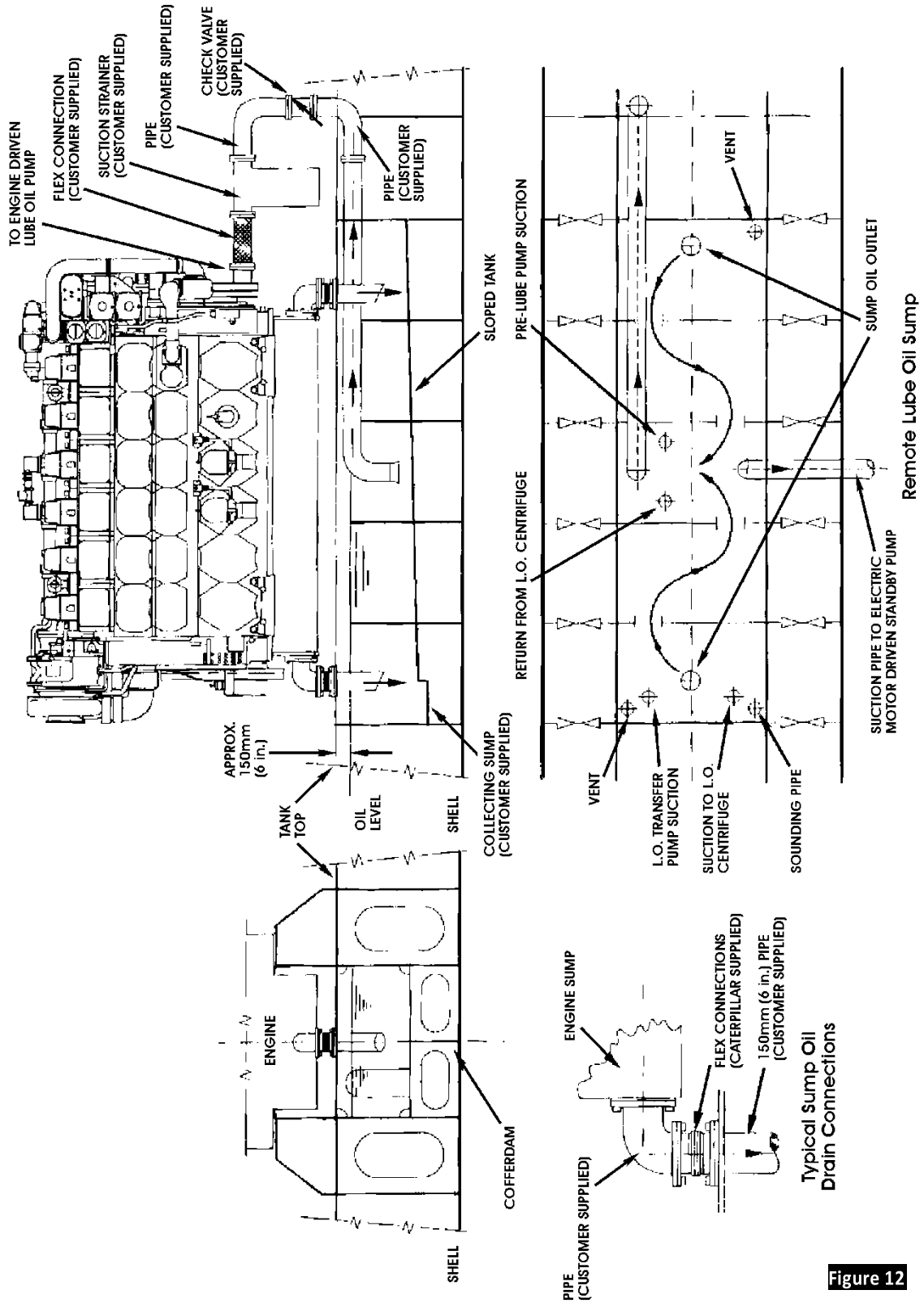

Figure 12

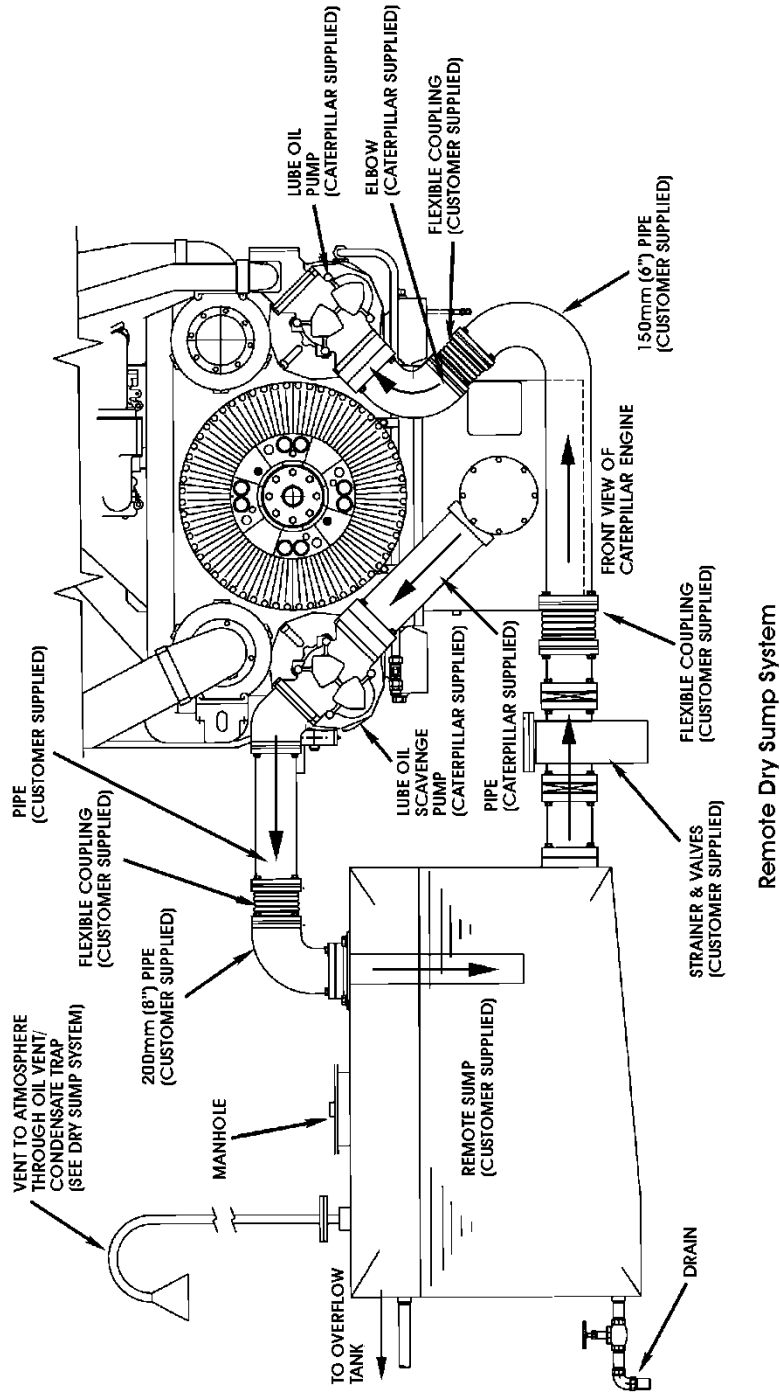
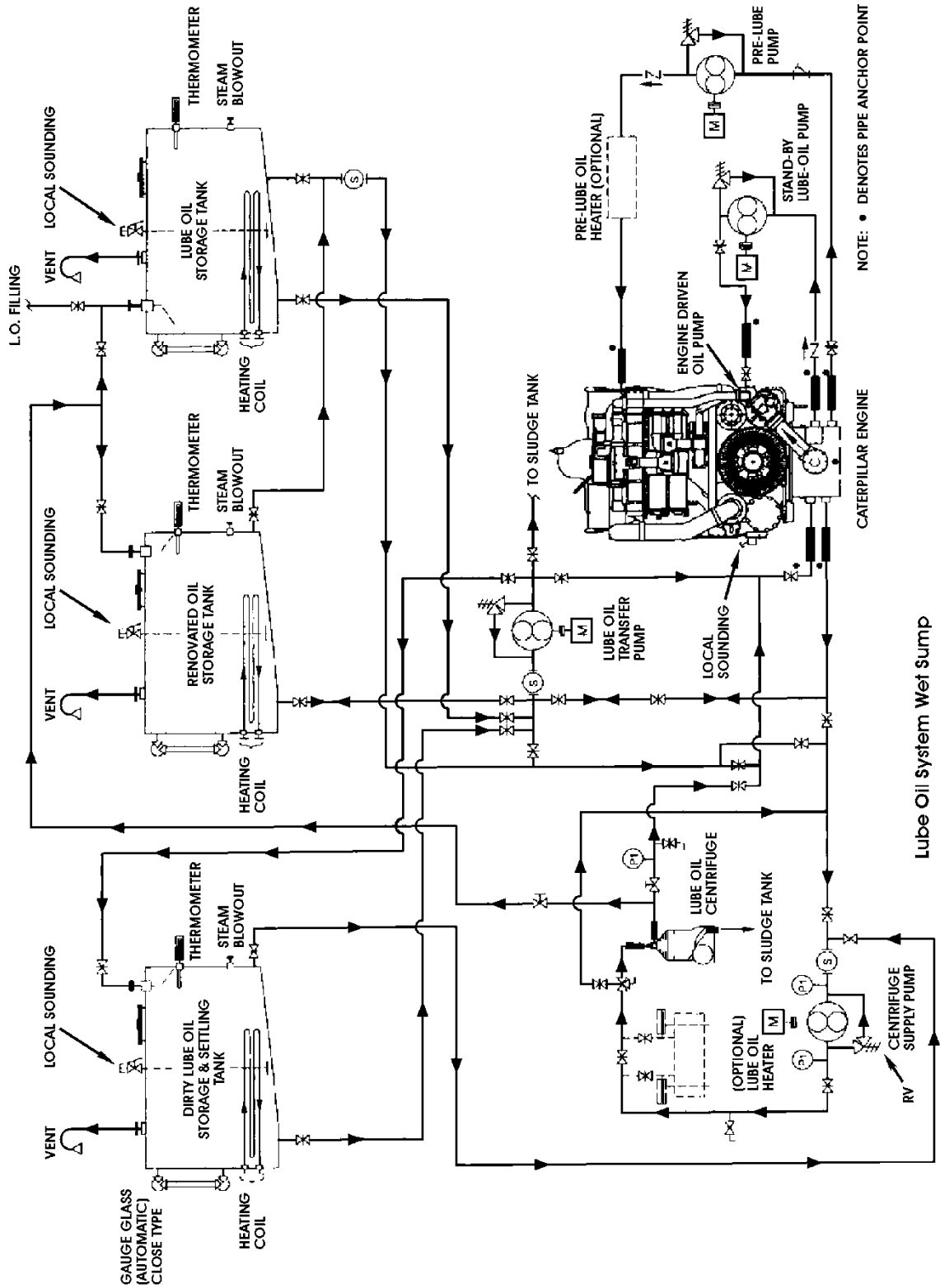

Figure 13

### 3600/G3600 Lube Oil System - Wet Sump Diagram



**Figure 14**



### 3600/G3600 Lube Oil System - Dry Sump Diagram

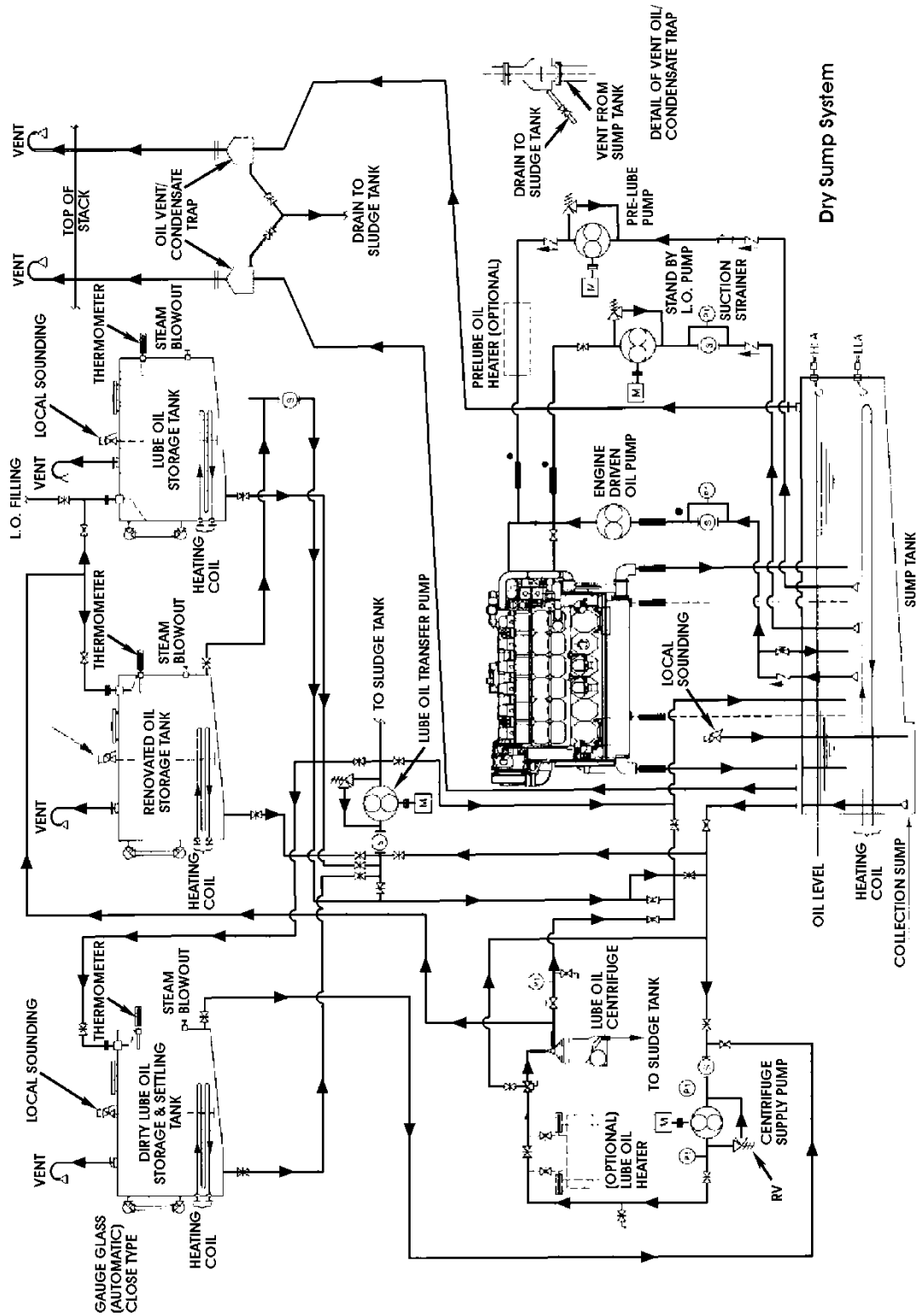

Figure 15

## Lubricating Oil Selection

Bearing failure, piston ring sticking and excessive oil consumption are classic symptoms of oil-related engine failure. There are numerous ways to avoid them. Three of the most important are S•O•S, regular maintenance of the lubrication system and the use of correct lubricants. Taking these measures can mean the difference between experiencing repeated oil-related engine failure and benefiting from a productive and satisfactory engine life.

The following information describes the properties of lubricating oil, as well as the consequences of oil contamination and degradation. Also discussed are methods of identifying contamination and degradation and preventive measures to help you protect your engine against the devastating effects of oil-related engine failure.

Please note that this information is supplemental and in no way replaces specific lubricating oil requirements for your application; nor does it preclude the need for oil analysis.

For model-specific information, refer to the Operation and Maintenance Manual for each engine.

### SECTION CONTENTS

|   |           |                                   |           |
|---|-----------|-----------------------------------|-----------|
| <b>Properties</b> .....                   | <b>43</b> | <b>Monitoring Quality</b> .....   | <b>47</b> |
| • Characteristics of<br>Lubricating Oil   |           | • S•O•S                           |           |
| • Components of Lubricating<br>Oil        |           | • Oil Analysis                    |           |
| • Caterpillar Line of Oils                |           | <b>Contamination</b> .....        | <b>48</b> |
| • Understanding TBN                       |           | • Contaminants and<br>Indications |           |
| <b>Consumption</b> .....                  | <b>46</b> |                                   |           |
| • Consumption Estimate<br>Formula         |           |                                   |           |
| • Consumption as an Overhaul<br>Indicator |           |                                   |           |

---

---

## Properties

### Viscosity

Viscosity is the property of resistance to flow in a fluid. Oil viscosity is its thickness or resistance to flow. Viscosity is directly related to how well an oil will lubricate and protect surfaces that contact one another. Oil must provide adequate supply to all moving parts, regardless of the temperature. The more viscous (thicker) an oil is, the stronger the oil film it will provide. The thicker the oil film, the more resistant it will be to being wiped or rubbed from lubricated surfaces. Conversely, oil that is too thick will have excessive resistance to flow at low temperatures and so may not flow quickly enough to those parts requiring lubrication. It is therefore vital that the oil has the correct viscosity at both the highest and the lowest temperatures at which the engine is expected to operate.

Oil thins out as temperature increases. The measurement of the rate at which it thins out is called the oil's viscosity index (VI). New refining techniques and the development of special additives which improve the oil's viscosity index help retard the thinning process.

The minimum temperature for the viscosity grade provides guidelines for the lowest starting temperature with a cold soaked engine. Caterpillar recommends using the highest viscosity oil possible. Even though the ambient temperature

may be low, operating engines can be subjected to normal oil temperatures because of temperature regulated components. The higher viscosity fluids will provide better protection to all components during the full day work cycle.

### Additives

Lubricating oil consists of a mixture of base oil fortified with certain additives. Depending on the type of base, paraffinic, asphaltic, naphthenic or intermediate (which has some of the properties of the former), different additive chemistries are used to strengthen or modify certain characteristics of the base oil.

The most common additives are detergents, oxidation inhibitors, dispersants, alkalinity agents, anti-wear agents, pour-point dispersants and viscosity improvers.

- Detergents help clean the engine by reacting with oxidation products to stop the formation of insoluble compounds.
- Oxidation inhibitors help prevent increases in viscosity, organic acids and carbonaceous matter.
- Dispersants help prevent sludge formation by keeping contaminants in suspension.
- Alkalinity agents help neutralize acids.

- Anti-wear agents reduce friction by forming a thin film on metal surfaces.
- Pour-point dispersants keep the oil fluid at low temperatures by preventing the growth and agglomeration of wax crystals.
- Viscosity improvers help prevent the oil from becoming too thin at high temperatures.

### **Total Base Number (TBN)**

Understanding TBN requires some knowledge of fuel sulfur content. Most diesel fuel contains some degree of sulfur. One of lubricating oils functions is to neutralize sulfur by-products, retarding corrosive damage to the engine. Additives in the oil contain alkaline compounds which are formulated to neutralize these acids. The measure of this reserve alkalinity in an oil is known as its TBN. Generally, the higher the TBN value, the more reserve alkalinity or acid-neutralizing capacity the oil contains.

The TBN value of an oil degrades during operation over time and can be used as a potential indicator of when to change oil.

### **Total Acid Number (TAN)**

High combustion temperatures in natural gas engines, especially lean-burn fuel systems, can rapidly deplete TBN and raise acid content in the oil. A TAN value higher than that of new oil may indicate oxidation or contamination.

TAN monitoring is especially important in engines using landfill gas.

### **Cleanliness**

Normal engine operation generates a variety of contamination, ranging from microscopic metal particles to corrosive chemicals. If the engine oil is not kept clean through filtration, this contamination would be carried through the engine via the oil.

Oil filters are designed to remove these harmful debris particles from the lubrication system. Use of a filter beyond its intended life can result in a plugged filter.

A plugged filter will cause the bypass valve to open, releasing unfiltered oil. Any debris particles in the oil will flow directly to the engine. When a bypass valve remains open, the particles that were previously trapped by the filter may also be flushed from it and then through the open bypass valve. Filter plugging can also cause distortion of the element. This happens when there is an unacceptable increase in the pressure difference between the outside and inside of the filter element. Distortion can progress to cracks or tears in the paper. This again allows debris to flow into the engine where it can damage components.

### **Engine Oil Selection**

Due to significant variations in quality and performance of commercially available oils, Caterpillar has developed its own line oil products for Cat engines.

The Caterpillar line of oils include Diesel Engine Oils (DEO), Natural Gas Engine Oils (NGEO) and Special Application Engine Oils (SAEO). DEO and NGEO are available in various viscosity grades to cover a broad range of operating temperatures. SAEO is used for products where

multi-grade oils are not appropriate. For instance, SAEO is recommended for engines equipped with mechanical unit injection. Additional reference on lubricating oil is available in the sources listed at the end of this guide.

## Consumption

Oil consumption is a consequence of normal engine operation. This oil needs to be replenished between maintenance intervals. Typical oil consumption figures are provided in the Technical Information Appendix for the purpose of predicting the quantity and cost of make up oil, as a part of total operating costs. In practice, many factors will affect oil consumption including load, oil density, oil additive packages and maintenance practices.

The rate of oil consumption is typically reported as brake-specific oil consumption (BSOC) so it is independent of operating load. To convert to a volume per hour basis, the engine load and oil density must also be known.

The following formula may be used to estimate oil consumption.

$$L/hr = \text{Engine } bkW \times \text{Load Factor } (\%) \times \frac{\text{BSOC (g/bkW-hr)}}{\text{Density of Oil}^{**}}$$

$$\text{gal/hr} = \text{Engine } bhp \times \text{Load Factor } (\%) \times \frac{\text{BSOC (lb/bhp-hr)}}{\text{Density of Oil}^{**}}$$

\*\*Typical engine oil has a density of 899 g/L (7.5lb/gal).

## Consumption as an Overhaul Guide

Oil consumption increases over time due to normal wear. Therefore, oil consumption rate can serve as an indicator of wear and used to predict the need for an overhaul. Caterpillar, however, recommends taking a more comprehensive approach. Trending engine output, measuring specific fuel consumption and measuring cylinder pressure are better tools for determining the need for an overhaul.

## Oil Change Interval

Caterpillar recommendations for oil change periods are published in Operation and Maintenance Manuals for each engine. As an alternative, change intervals can be established by a comprehensive maintenance management program that includes oil condition analysis. Caterpillar offers such a program. It is the **S•O•S** services program.

---

## Monitoring Quality

Monitoring lubrication quality can maximize the life of engine oil and provide optimum protection for the internal engine components.

### S•O•S

The Caterpillar tool for oil analysis is S•O•S, which is part of the S•O•S services program. This program determines oil change intervals based on condemning limits and trend analysis established for the engine. It also looks for the presence of oil contaminants, which are used to analyze the condition of the engine, indicate shortcomings in engine maintenance and detect the first signs of excessive wear.

Sampling intervals differ for various engines and applications. Refer to the Operation and Maintenance Manual for appropriate intervals or contact your Cat dealer.

The S•O•S testing includes wear analysis, oil condition analysis and additional chemical and physical tests. Contact your Cat dealer for complete information and assistance on the S•O•S services program.

### Wear Analysis

Wear analysis monitors component wear rate by identifying and measuring concentrations of wear elements in oil. Based on known normal concentration data, maximum limits of wear elements are established. After three oil samples are taken, trend lines for

the various wear elements can be established for the particular engine. Impending failures can be identified when trend lines deviate from the established norm.

Wear analysis is limited to detecting component wear and gradual dirt contamination. Failures due to component fatigue, sudden loss of lubrication or sudden ingestion of dirt occur too rapidly to be predicted by this type of test.

### Oil Condition Analysis

Oil condition analysis determines the amount of contaminants, such as soot and sulfur, oxidation and nitration products. Results can be used to customize (reduce, maintain, or extend) oil change intervals for particular conditions and applications.

### Additional Tests

Chemical and physical tests detect water, fuel and antifreeze in the oil and determine whether or not their concentrations exceed established limits.

---

## Contamination

The following are examples of typical contaminants and the affect they have on the condition of your engine. Engine operating conditions can also play a major role in the type and degree of oil contamination. For a more thorough discussion of this topic, refer to Applied Failure Analysis – Oil and Your Engine, Media Number SEBD0640.

### Copper

A high concentration of copper indicates thrust washer or bushing wear.

### Silicon

Above normal readings of silicon can indicate a major problem. Oil loaded with silicon becomes, in effect, a grinding compound which can remove metal from any number of parts during operation.

### Sodium, Silicates, Carboxylic Acid Base

A sudden increase in sodium, silicates, or carboxylic acid base readings indicate inhibitor leaking from the cooling system. Inhibitor may indicate antifreeze in the system which can cause oil to thicken and become like sludge, leading to piston ring sticking and filter plugging.

### Silicon, Chromium, Iron, Aluminum

A combination such as this signals dirt entry through the air induction system, possibly causing ring and liner wear.

### Silicon, Lead, Aluminum, Tin

This combination indicates dirt in the lower portion of the engine, possibly leading to crankshaft and bearing wear.

### Chromium, Molybdenum, Aluminum

This combination can lead to ring and piston wear, resulting in blow-by, increased oil consumption and oil degradation.

### Aluminum

This can be a critical concern. Concentrations of aluminum suggest bearing wear. Relatively small increases in the levels of this element should receive immediate attention because, once rapid wear begins, the crankshaft may produce large metal particles which will become trapped in the oil filters.

### Iron

Iron can come from any number of sources. It can also appear as rust after engine storage. Frequently, when accompanied by a loss of oil control, increases in iron contamination indicate severe liner wear.

### Soot

A high soot content is not usually the direct cause of failure. Solid particles do not dissolve in the oil, causing the filters to become plugged and depleting dispersant additives. Soot indicates a dirty air cleaner, engine lug, excessive fuel delivery, or repeated acceleration in



the improperly set rack limiter (smoke limiter). It can also indicate a poor quality fuel.

## **Water**

Water combined with oil will create an emulsion which will plug the filter. Water and oil can also form a dangerous metal corroding acid. Most instances of water contamination are the result of condensation within the crankcase. More serious contamination occurs when a leak in the cooling system allows water to enter from outside the engine oil system.

## **Fuel**

Fuel contamination decreases the oil's lubricating properties. The oil no longer has the necessary film strength to prevent metal-to-metal contact. This can lead to bearing failure and piston seizure.

## **Sulfur**

The presence of sulfur signals danger to all engine parts. The type of corrosive wear attributed to high sulfur content can also cause accelerated oil consumption. The more fuel consumed during an oil change interval, the more sulfur oxides are available to form acids. Therefore, an engine working under heavy loads should have its oil checked more often, including its TBN, which relates directly to an oil's ability to neutralize sulfur by-products. Fuel sulfur damage can cause piston ring sticking and corrosive wear of the metal surfaces of valve guides, piston rings and liners.

## Reference Material

The following information is provided as additional reference to subjects discussed in this manual.

The following service publications provide comprehensive information on lubricating oil, as well as other fluids used in Cat engines.

Although Cat brand oil is the only oil Caterpillar endorses, these guides also provide minimum requirements for commercially available oils.

**SEBD0640**

Oil And Your Engine

**LEBW4958**

Application and Installation Guide,  
Crankcase Ventilation

**SEBU6251**

Caterpillar Commercial Diesel  
Engine Fluids Recommendations

**SEBU6400**

Caterpillar Gas Engine Lubricant,  
Fuel and Coolant  
Recommendations

**SEBU7003**

3600 Diesel Engine Fluids  
Recommendations for Lubricants,  
Fuels and Coolants

**PEDP7036**

S•O•S Fluid Analysis

**WECAP**

Web Engineering Cataloging and  
Procuring website

[www.cat.com/power-systems](http://www.cat.com/power-systems)

**BUILT FOR IT.™**

LEBW4957-04

Information contained in this publication may be considered confidential. Discretion is recommended when distributing. Materials and specifications are subject to change without notice.

©2018 Caterpillar. All rights reserved. CAT, CATERPILLAR, BUILT FOR IT, their respective logos, S•O•S, HEUI, "Caterpillar Yellow", "Power Edge" trade dress as well as corporate and product identity used herein, are trademarks of Caterpillar and may not be used without permission.

