

Picture shown may not reflect actual configuration.

Cat® BDP1000 Bi-Directional Energy Storage Inverter

The Cat® BDP1000 bi-directional energy storage inverter provides reliable control of the Energy Storage System (ESS). Integrated controls provide complete management of the charge and discharge of the ESS. The BDP1000 is a high-performance inverter designed with the flexibility to be used in both grid connected and off grid applications. Well suited for use in parallel with generators, photovoltaic, wind turbines and hydroelectric power sources.

Features

Functionality

Injects or absorbs real power and reactive power at the AC bus. Can be paired with varying sizes and types of energy storage devices.

Dual Parallel Inverter

Robust liquid cooled dual parallel inverters offer independent control for flexibility of system optimization and partial system fault tolerance.

Multiple Modes with Seamless Transfer

Seamless transfer between grid forming, grid firming and grid following mode (subject to grid and local load conditions).

Microgrid Transient Stability

Stabilizes a microgrid against transient events caused by step loads and fluctuating renewable power sources.

Patented Non-Linear Droop Control

- Ultra-fast response with reduced dead bands.
- Overall lower frequency deviation and improved power quality in off grid operation.

Energy Storage Management

Built-in controls for charging, discharging, equalization, and state-of-charge estimation for energy storage elements. Operational in Autonomous or Remote-Control modes (works in conjunction with supervisory controller).

Applicable Standards and Certifications

- UL Listed to the following standards (cULus certification and mark):
 - UL 1741 SA
 - UL 1741 SB (pending)
 - IEEE1547-2018
 - IEEE1547.1-2020
 - UL1998
 - CSA C22.2 No. 107.1:16
 - CSA C22.3 (pending)
- CE Declaration of Conformity:
 - IEC62477-1 (pending)
 - IEC62909 (pending)

Islanding Detection

Automatic islanding detection to meet anti- islanding UL1741/IEEE1547 and synchronization back to grid to guarantee continuous power to the load.

Touch Screen

User friendly touch-screen display offers real-time system information, configurable data logging, remote access, and more.

Parallel Ready

Plug-and-play paralleling with other power sources.

Technical Specifications ⁽¹⁾

Multiple Modes	Control Functionality
Grid Forming ("Isochronous" Droop Control)	The BDP maintains a frequency target that is derived from frequency droop calculation. Frequency commanded to FPGA (field programmable gate array) and that frequency varies with load.
Grid Firming	The BDP will inject or absorb power based on a deviation from nominal voltage or nominal frequency. <ul style="list-style-type: none"> • Power is in proportion to the voltage (inject/absorb reactive power) or frequency (inject/absorb real power) • Primarily used when paralleling BDP1000 with Gensets
Grid Following	The BDP will inject or absorb current to meet a defined target real power and target reactive power. <ul style="list-style-type: none"> • Target Power value is the aggregate value of the BDP1000 dispatch command and any IEEE1547-2018 Grid-Support requirements.

NOTE: Control mode functionality described above is always limited by BDP1000 hardware capability

Configuration	
DC Input Voltage	800 VDC to 1000 VDC
Max. Continuous DC Input Current	1250A
DC Isolating Switch	Contactors and Manual Disconnect with Lockout Feature
Rated Output Power	1000 kVA
Rated Output Power 0.9 PF Rated Output Power 0.8 PF Rated Output Power 0.7 PF	900 kW [Reactive Power 440 kVAR] @ 850-950 DCV 800 kW [Reactive Power 596 kVAR] @ 850-950 DCV 700 kW [Reactive Power 710 kVAR] @ 885-950 DCV
Overload Capacity	150% for 10 sec (preliminary) 125% for 4 mins (preliminary)
Fault Current Capability	2 per unit (P.U.)
Output Voltage Range (L-L) from transformer ⁽²⁾	380 - 600V
Output Frequency Range ⁽³⁾	50 or 60 Hz
Output Power Factor	Controllable from Supervisory Controller
Total Harmonic Distortion	<3%
AC Disconnect and Protection	Electrically Operated Breaker with LSI ⁽⁵⁾ Trip Unit
Peak Efficiency ⁽⁴⁾	98%
CEC Weighted Efficiency ⁽⁴⁾	97% (preliminary)
Communication and Control Interface	Modbus TCP, SunSpec, others configurable on request and via MMC DNP3 ⁽⁶⁾
HMI Interface	10 Inch Color HMI Touchscreen
Seamless Transition between Charging and Discharging	-1000 kW to 1000 kW
Mode Switch from Grid follow to Grid form Total source transition time	within 30 ms (via modbus command) within 5 ms (via analog input)
Output Voltage	+5% / -10% Adjustable
AC Voltage Regulation	± 1%
Black Start Capability	Yes (built-in UPS module for control power)
Ambient Temperature	-20°C to + 30°C
Vibration	3.5G Peak with 1000 Cycles
Humidity	0-95%
Cooling	Closed-Loop Liquid Cooling Inlet: -40°C to + 60°C with Overload Operational

⁽¹⁾ Data is for linear load(s). Ensure compatibility of all microgrid equipment by referring to A&I guides (or equivalent) for generator sets, BDP inverters, PV inverters, switchgear, and controls. Contact your local Cat dealer for assistance selecting compatible equipment.

⁽²⁾ Voltage is dependent on selection of Isolation Transformer

⁽³⁾ Please consult factory for 50Hz technical data and product availability.

⁽⁴⁾ Excluding isolation transformer

⁽⁵⁾ LSI (long-time, short-time and instantaneous)

⁽⁶⁾ Distributed Network Protocol (DNP)

Potential Applications of BDP (7)

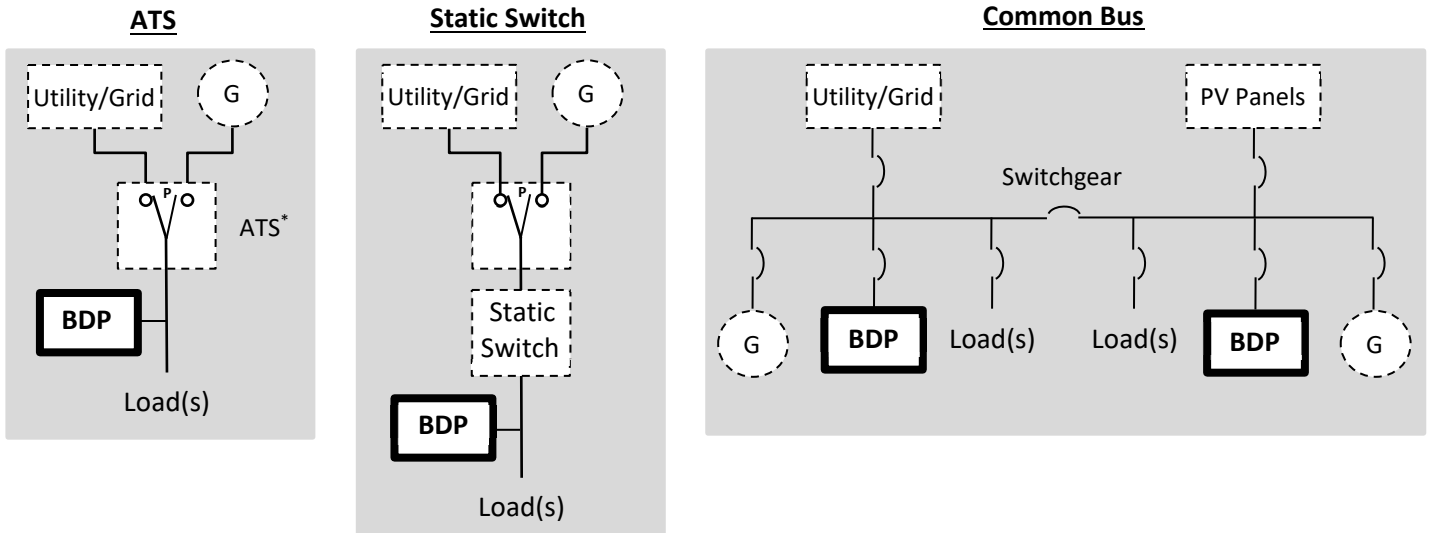

(7) For system connected to non-linear load(s) consult factory for performance modeling assistance.
* Closed transition automatic transfer switch (ATS).

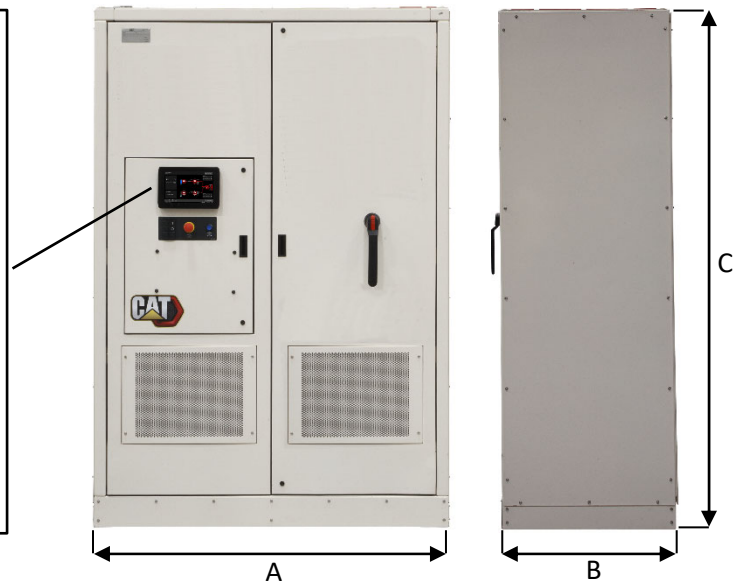

High-Resolution LCD	
Colors	16.7 million
Backlight	LED
Resolution 10"	1280 x 800

Dimensions			
A	B	C	Weight dry
mm (in)	mm (in)	mm (in)	kg (lbs)
1509 (59.4)	709 (27.9)	2190 (86.2)	1495 (3296)

Materials and specifications are subject to change without notice.
CAT, CATERPILLAR, LET'S DO THE WORK, their respective logos, "Caterpillar Corporate Yellow", the "Power Edge" and Cat "Modern Hex" trade dress as well as corporate and product identity used herein, are trademarks of Caterpillar and may not be used without permission.